

Legislative #

140501A

ORDINANCE NO. 140501

1
2
3
4
5
6
7
8
9
10
11
12
13
14
15
16
17
18
19
20
21
22
23
24
25
26
27

An ordinance of the City of Gainesville, Florida, adopting a Master Signage Plan to regulate signage within the Butler Development, a Planned Development (PD) zoning district that consists of approximately 267 acres generally located north of SW Archer Road, south of SW 24th Avenue, east of SW 40th Boulevard, and west of SW 34th Street; providing for enforcement; providing a severability clause; providing a repealing clause; and providing an immediate effective date.

WHEREAS, the Butler Development is a private development consisting of approximately 267 acres within the City of Gainesville that is generally located north of SW Archer Road, south of SW 24th Avenue, east of SW 40th Boulevard, and west of SW 34th Street; and

WHEREAS, the parcels of property that comprise Butler Development are owned separately, not jointly, by two legal entities: 1) S. Clark Butler Properties Corporation, a Florida corporation, acting as General Partner of S. Clark Butler Properties, Ltd., a Florida limited partnership, and 2) Esplanade Capital, LLC (the “Owners”); and

WHEREAS, on November 21, 2013, the City Commission adopted Ordinance No. 121108 and rezoned Butler Development to Planned Development District (PD), which is a zoning category that allows for landowners or developers to submit unique proposals that are not addressed or otherwise provided for in the zoning districts and land development regulations established by the City of Gainesville Land Development Code; and

WHEREAS, Section 163.3164(26), Florida Statutes, defines “land development regulations” as ordinances enacted by governing bodies for the regulation of any aspect of the development of land and shall specifically include any local government zoning, rezoning, subdivision, building construction, and sign regulations; and

1 **WHEREAS**, Section 163.3202(2), Florida Statutes, requires each municipality to adopt
2 by ordinance and enforce certain land development regulations, which shall include the
3 regulation of signage amongst other land development regulations; and

4 **WHEREAS**, Section 163.3194(2), Florida Statutes, provides that a municipality may not
5 adopt a land development regulation ordinance until such land development regulation has been
6 referred to a local planning agency for review and recommendation; and

7 **WHEREAS**, Section 30-214 of the Land Development Code specifies certain land
8 development regulations that a PD zoning ordinance may include, such as a unified signage plan
9 that will regulate signage within the PD in a unique and innovative manner that is not provided
10 for in the sign regulations in the Land Development Code but is nevertheless consistent with and
11 promoted by the City of Gainesville Comprehensive Plan; and

12 **WHEREAS**, PD Ordinance No. 121108 includes a provision that allows the Owners to
13 submit a Master Signage Plan that will regulate signage within the Butler Development, subject
14 to review and approval by the City Commission (*see* Exhibit “C” to Ordinance No. 121108, page
15 19 of 47, #7); and

16 **WHEREAS**, in accordance with PD Ordinance No. 121108, the Owners have submitted
17 a Master Signage Plan that will regulate signage within the Butler Development; and

18 **WHEREAS**, on October 23, 2014, a public hearing was held by the City Plan Board,
19 which acts as the local planning agency pursuant to Section 163.3174, Florida Statutes, where it
20 provided comments regarding the Butler Development Master Signage Plan; and

21 **WHEREAS**, at least ten (10) days’ notice has been given once by publication in a
22 newspaper of general circulation notifying the public of this proposed ordinance and of public

1 hearings in the City Hall Auditorium located on the first floor of City Hall in the City of
2 Gainesville; and

3 **WHEREAS**, public hearings were held pursuant to the notice described above at which
4 hearings the parties in interest and all others had an opportunity to be and were, in fact, heard;
5 and

6 **WHEREAS**, the City Commission recognizes that signs may present a safety hazard by
7 distracting motorists, pedestrians and other members of the public and may affect the aesthetic
8 qualities and economic vitality of the community, and that these concerns are of a substantial
9 interest to the City of Gainesville; and

10 **WHEREAS**, the City Commission finds that the signage regulations provided in the
11 Butler Development Master Signage Plan are consistent with and promote the Comprehensive
12 Plan and that such signage regulations are reasonable and narrowly tailored to directly preserve
13 and protect the health, safety, welfare, and general well-being of citizens by promoting public
14 safety, economic vitality, and aesthetic qualities in the City of Gainesville.

15 **NOW, THEREFORE, BE IT ORDAINED BY THE CITY COMMISSION OF THE**
16 **CITY OF GAINESVILLE, FLORIDA:**

17 **Section 1.** The Butler Development Master Signage Plan, attached to this ordinance
18 as Exhibit “A” and incorporated herein by reference as if set forth in full, is adopted to regulate
19 signage within the Butler Development and shall replace and supersede the signage regulations
20 provided in PD Ordinance No. 121108 (Pages 18,19 of 47 in Exhibit “C” to Ordinance No.
21 121108). All signage within the Butler Development shall meet the signage regulations set forth
22 in the City of Gainesville Land Development Code in effect at the time of application for a sign

1 permit, except as expressly provided by the Butler Development Master Signage Plan attached to
2 this ordinance as Exhibit "A".

3 **Section 2.** Any person who violates any provision of this ordinance shall be deemed guilty
4 of a municipal ordinance violation and shall be subject to fine or imprisonment as provided by
5 Section 1-9 of the Gainesville Code of Ordinances. Each day a violation occurs or continues,
6 regardless of whether such violation is ultimately abated or corrected, shall constitute a separate
7 offense.

8 **Section 3.** If it is determined by the City Manager that a violation of this ordinance exists,
9 the City Manager may issue and deliver an order to cease and desist from such violation in order to
10 correct a violation. The City Manager, through the City Attorney, may seek an injunction in a court
11 of competent jurisdiction and seek any other remedy available at law.

12 **Section 4.** If any word, phrase, clause, paragraph, section or provision of this ordinance
13 or the application hereof to any person or circumstance is held invalid or unconstitutional, such
14 finding shall not affect the other provisions or applications of this ordinance that can be given
15 effect without the invalid or unconstitutional provision or application, and to this end the
16 provisions of this ordinance are declared severable.

17 **Section 5.** Except as expressly modified or superseded herein, Ordinance No. 121108 shall
18 remain in full force and effect. In the event of conflict or inconsistency between the provisions of
19 Ordinance No. 121108 and this ordinance, this ordinance shall govern and prevail.

20 **Section 6.** This ordinance shall become effective immediately upon adoption.
21
22

1 **PASSED AND ADOPTED** this ____ day of _____, 2015.

2
3
4
5
6
7

EDWARD B. BRADDY
MAYOR

8 Attest:

Approved as to form and legality:

9
10
11

KURT M. LANNON
CLERK OF THE COMMISSION

NICOLLE M. SHALLEY
CITY ATTORNEY

14

15 This ordinance passed on first reading this ____ day of _____, 2015.

16

17 This ordinance passed on second reading this ____ day of _____, 2015.

EXHIBIT "A" TO ORDINANCE NO. 140501

**BUTLER DEVELOPMENT
MASTER SIGNAGE PLAN**

December 4th, 2014

TABLE OF CONTENTS

<u>SECTION</u>	<u>PAGE</u>
I. SIGN LOCATION MAP	3
II. GENERAL SIGNAGE STANDARDS	4
III. LANDMARK SIGN	5
IV. PROJECT ENTRY SIGNS	
A. TYPE 1	6
B. TYPE 2	7
V. MONUMENT SIGNS	8
VI. OUTPARCEL SIGNS	9
VII. PROJECT DIRECTIONAL SIGNS	10
VIII. VEHICULAR DIRECTIONAL SIGNS	11
IX. POLE BANNERS	12
X. WALL SIGNS	13
XI. AWNING, UNDER-CANOPY/PROJECTING, BLADE, AND MARQUEE SIGNS	14
XII. PEDESTRIAN SIGNS	15
XIII. TEMPORARY SIGNS	16
XIV. AMORTIZATION OF EXISTING SIGNS	17

I. Sign Location Map

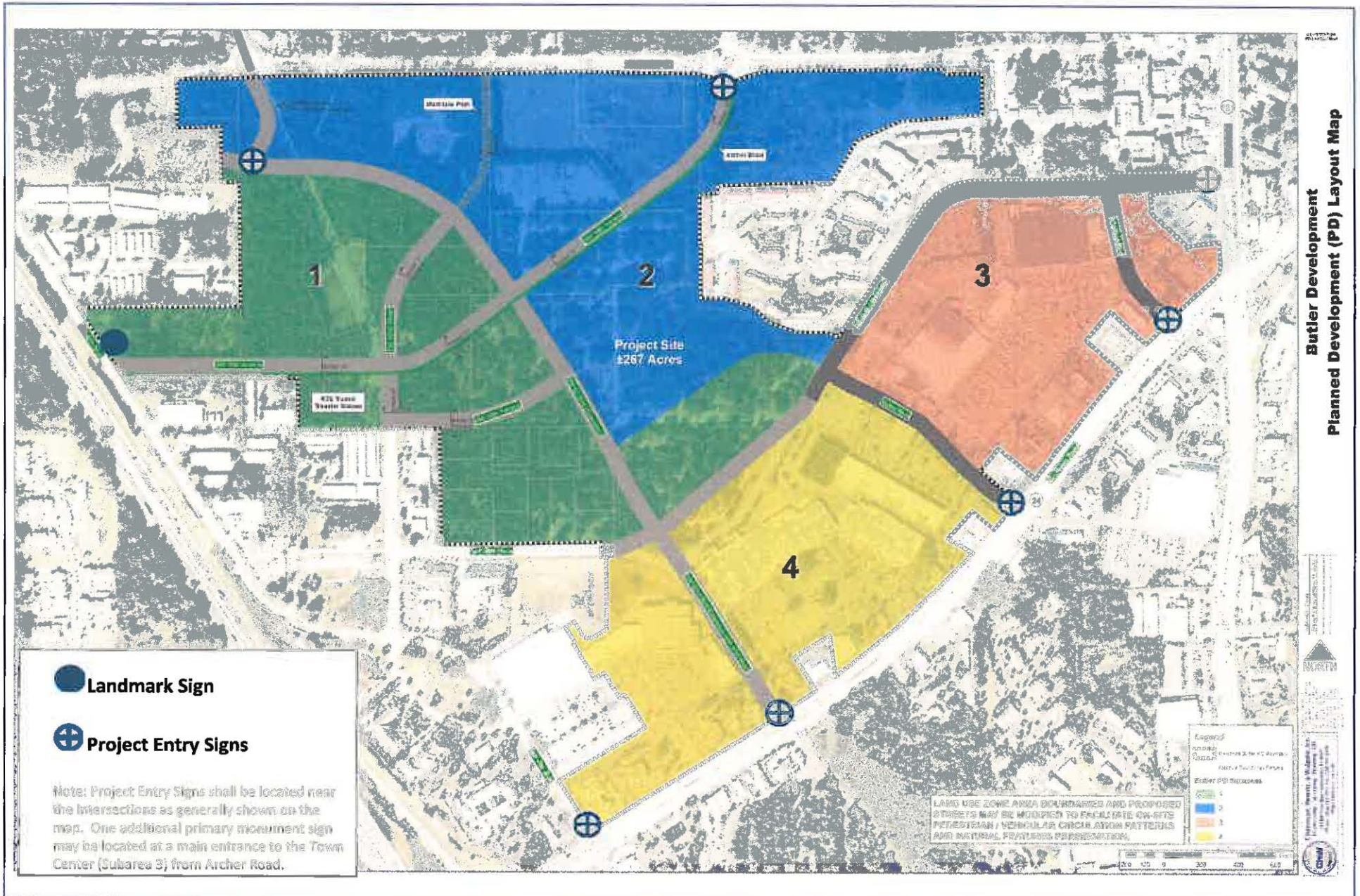

II. General Signage Standards

- A. ALL SIGNAGE WITHIN THE BUTLER DEVELOPMENT SHALL MEET THE SIGNAGE REGULATIONS SET FORTH IN THE CITY OF GAINESVILLE LAND DEVELOPMENT CODE IN EFFECT AT THE TIME OF APPLICATION FOR A SIGN PERMIT, EXCEPT AS EXPRESSLY PROVIDED BY THIS BUTLER DEVELOPMENT MASTER SIGNAGE PLAN.
- B. ALL SIGNS SHALL CONVEY THE CHARACTER, THEMES, AND ARCHITECTURAL DESIGN CONSISTENT WITH THE PLANNED DEVELOPMENT AND THE FOUR SUBAREAS.
- C. SIGNS MAY BE PLACED ON PROPERTY LINES WITHIN THE DEVELOPMENT AND NO MINIMUM SETBACKS ARE REQUIRED.
- D. WITHIN THE TOWN CENTER, PROJECT ENTRY AND DIRECTIONAL SIGNS SHALL BE DESIGNED AS ARCHITECTURAL FEATURES, AND THEY SHALL BE COMPATIBLE WITH AND COMPLEMENT THE ADJACENT BUILDINGS. THEY SHALL BE LOCATED ON STRUCTURES OR FRAMES BETWEEN BUILDINGS AT ARCADES, COLONNADES, OR SIMILAR FEATURES.
- E. WITHIN THE TOWN CENTER, ALL VEHICULAR DIRECTIONAL SIGNS SHALL BE OF A TYPE WITH DECORATIVE POST(S) AND FINIALS TO MATCH STREET LIGHTING.

III. Landmark Sign

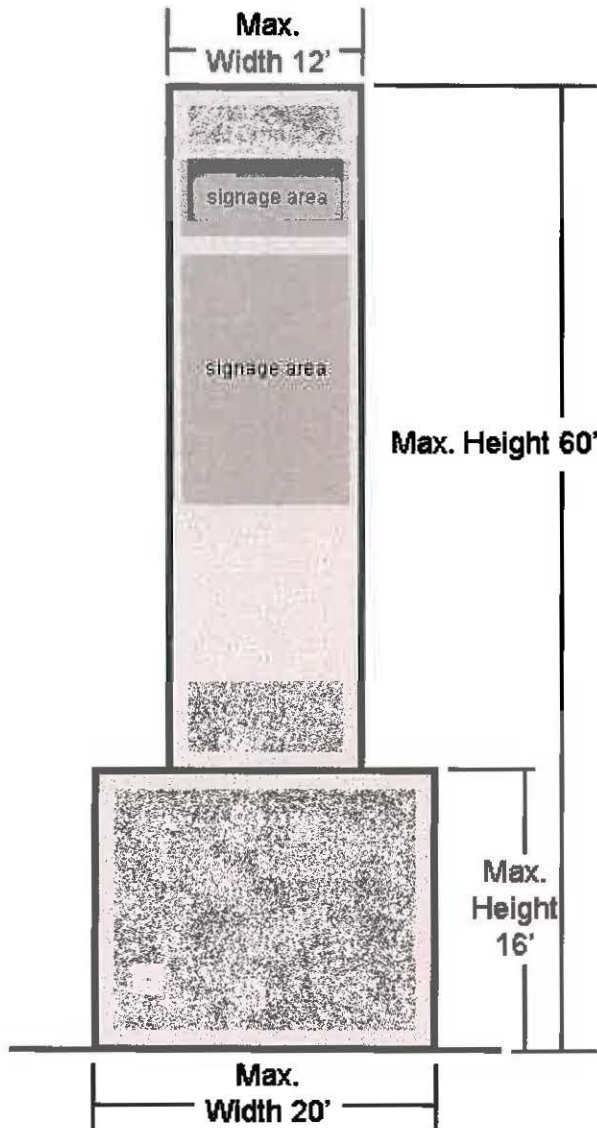

LOCATION: SUB-AREA 1 AT I-75

MAX. HEIGHT: 60'

MAX. WIDTH: 12' (20' BASE)

MAX. SIGN AREA: 105 SQ FT PER SIDE FOR NAME OF BUTLER DEVELOPMENT
740 SQ FT PER SIDE MAY ADVERTISE ANY OCCUPANT WITHIN BUTLER DEVELOPMENT

MATERIALS: MASONRY OR STUCCO OR SIMILAR MATERIAL

LIGHTING: SIGN FACE MAY BE EXTERNALLY ILLUMINATED;
STRUCTURE MAY CONTAIN EXTERNAL OR INTERNAL ACCENT LIGHTING

NOTE: A SINGLE LANDMARK SIGN IS ALLOWABLE WITHIN THE BUTLER DEVELOPMENT, AS SHOWN ON THE SIGN LOCATION MAP.

IV.A. Project Entry Sign Type 1

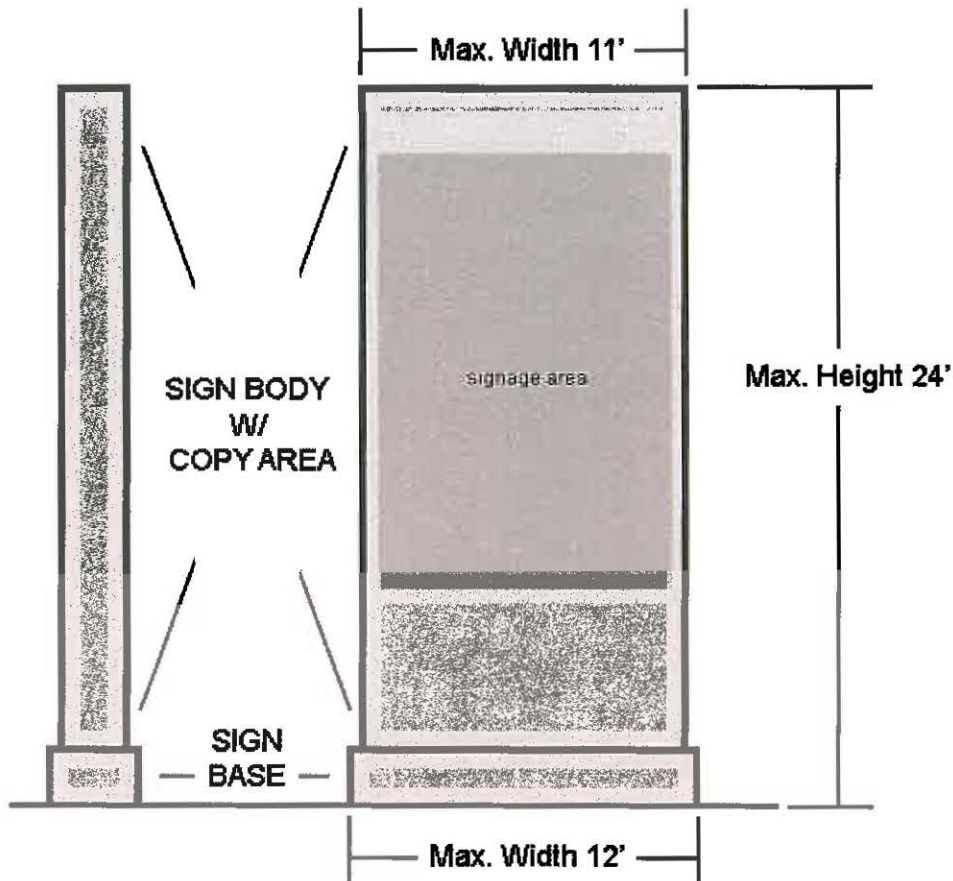

LOCATION: SHALL BE LIMITED TO ONE TYPE 1 OR TYPE 2 AT EACH OF THE FOLLOWING INTERSECTIONS/LOCATIONS:

- ARCHER ROAD AT SW 40TH BOULEVARD
- ARCHER ROAD AT SW 62ND BOULEVARD
- ARCHER ROAD AT SW 35TH BOULEVARD
- ARCHER ROAD AT BRATCHER BOULEVARD
- SW 62ND BOULEVARD AT SW 43RD STREET
- SW 38TH TERRACE AT SW 24TH AVENUE
- WINDMEADOWS BOULEVARD AT SW 34TH STREET
- MAIN ENTRANCE TO TOWN CENTER AT ARCHER ROAD (THIS LOCATION IS NOT DEPICTED ON THE SIGN LOCATION MAP AS IT HAS NOT YET BEEN DETERMINED.)

MAX. HEIGHT:	24'
MAX. WIDTH:	11' (12' BASE)
MAX. SIGN AREA:	180 SQ FT PER FACE
MATERIALS:	ALUMINUM BODY (OR SIMILAR), CONCRETE BASE
LIGHTING:	MAY BE INTERNALLY OR EXTERNALLY ILLUMINATED
NOTE:	MAY CONTAIN THE BUTLER DEVELOPMENT NAME/LOGO, AND ADVERTISE ANY OCCUPANT(S) WITHIN THE BUTLER DEVELOPMENT.

IV.B. Project Entry Sign Type 2

LOCATION: SHALL BE LIMITED TO ONE TYPE 1 OR TYPE 2 AT EACH OF THE FOLLOWING INTERSECTIONS/LOCATIONS:

- ARCHER ROAD AT SW 40TH BOULEVARD
- ARCHER ROAD AT SW 62ND BOULEVARD
- ARCHER ROAD AT SW 35TH BOULEVARD
- ARCHER ROAD AT BRATCHER BOULEVARD
- SW 62ND BOULEVARD AT SW 43RD STREET
- SW 38TH TERRACE AT SW 24TH AVENUE
- WINDMEADOWS BOULEVARD AT SW 34TH STREET
- MAIN ENTRANCE TO TOWN CENTER AT ARCHER ROAD (THIS LOCATION IS NOT DEPICTED ON THE SIGN LOCATION MAP AS IT HAS NOT YET BEEN DETERMINED.)

MAX. HEIGHT: 15'
 MAX. WIDTH: 24' PER SIDE
 MAX. SIGN AREA: 115 SQ FT PER FACE PER SIGN
 MATERIALS: ALUMINUM BODY (OR SIMILAR), CONCRETE BASE
 LIGHTING: MAY BE INTERNALLY OR EXTERNALLY ILLUMINATED
 NOTE: MAY CONTAIN THE BUTLER DEVELOPMENT NAME/LOGO, AND ADVERTISE ANY OCCUPANT(S) WITHIN THE BUTLER DEVELOPMENT.



V. Monument Signs

LOCATION: MAY BE LOCATED ON A MAXIMUM OF THREE (3) SIDES OF ANY SINGLE OR MULTIPLE OCCUPANCY DEVELOPMENT THAT HAS FRONTAGE ON A PUBLIC STREET, PRIVATE STREET, OR MANEUVERING LANE.

MAX. HEIGHT:	14'
MAX. WIDTH:	15' (EXCLUDING THE BASE)
MAX. SIGN AREA:	110 SQ FT PER FACE
MATERIALS:	ALUMINUM BODY (OR SIMILAR), CONCRETE BASE
LIGHTING:	MAY BE INTERNALLY OR EXTERNALLY ILLUMINATED
LIMITATIONS:	MAY ONLY BE PLACED AT VEHICULAR ENTRANCES TO A DEVELOPMENT, AND MAY NOT BE PLACED AT LOCATIONS APPROVED FOR PROJECT ENTRY SIGNS.
NOTE:	MAY CONTAIN THE BUTLER DEVELOPMENT NAME/LOGO, DIRECTIONAL INFORMATION, AND ADVERTISE ANY OCCUPANT(S) WITHIN THE SINGLE OR MULTIPLE OCCUPANCY DEVELOPMENT SITE ON WHICH THE SIGN IS LOCATED.

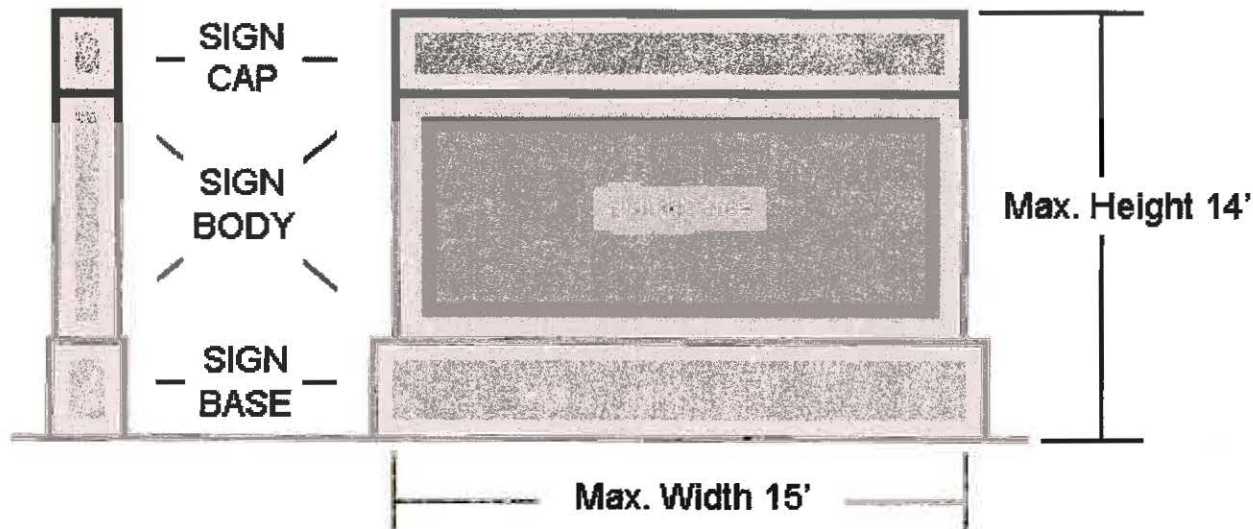

VI. Outparcel Signs

OUTPARCEL SIGNS

NUMBER:	ONE (1) MONUMENT-STYLE SIGN WITH TWO SIDES PER OUTPARCEL
LOCATION:	MAY BE LOCATED ALONG ANY PUBLIC STREET, PRIVATE STREET, OR MANEUVERING LANE WHERE THE OUTPARCEL HAS FRONTAGE
MAX. HEIGHT:	8'
MAX. SIGN WIDTH:	5' (EXCLUDING THE BASE)
MAX SIGN AREA:	32 SQ FT PER SIGN FACE
MATERIALS:	ALUMINUM BODY (OR SIMILAR), CONCRETE BASE
LIGHTING:	MAY BE INTERNALLY OR EXTERNALLY ILLUMINATED
NOTE:	MAY CONTAIN THE BUTLER DEVELOPMENT NAME/LOGO AND ADVERTISE ANY OCCUPANT(S) WITHIN THE OUTPARCEL ON WHICH THE SIGN IS LOCATED.

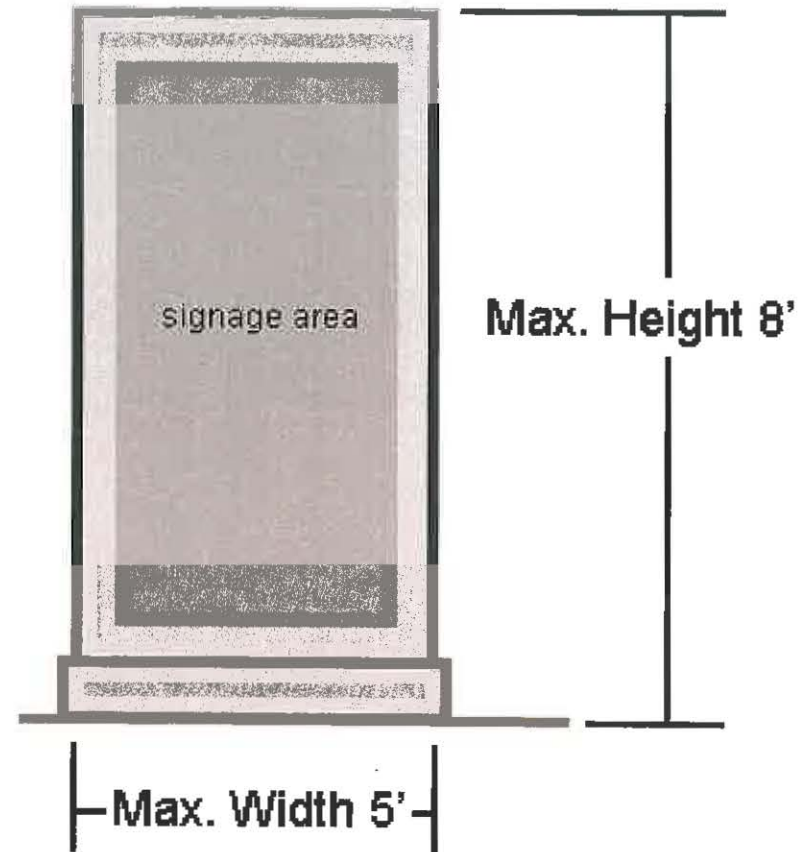

VII. Project Directional Sign

DIRECTIONAL SIGN TYPE 1

MAX. HEIGHT: 8'

MAX. SIGN WIDTH: 3'

MAX. SIGN AREA: 24 SQ FT PER SIGN FACE

MATERIALS: ALUMINUM BODY (OR SIMILAR)

LIGHTING: MAY BE INTERNALLY OR EXTERNALLY ILLUMINATED

NOTE: MAY BE PROVIDED TO DIRECT PEOPLE TO ANY OCCUPANT(S) WITHIN THE BUTLER DEVELOPMENT OR COMMON AREAS.

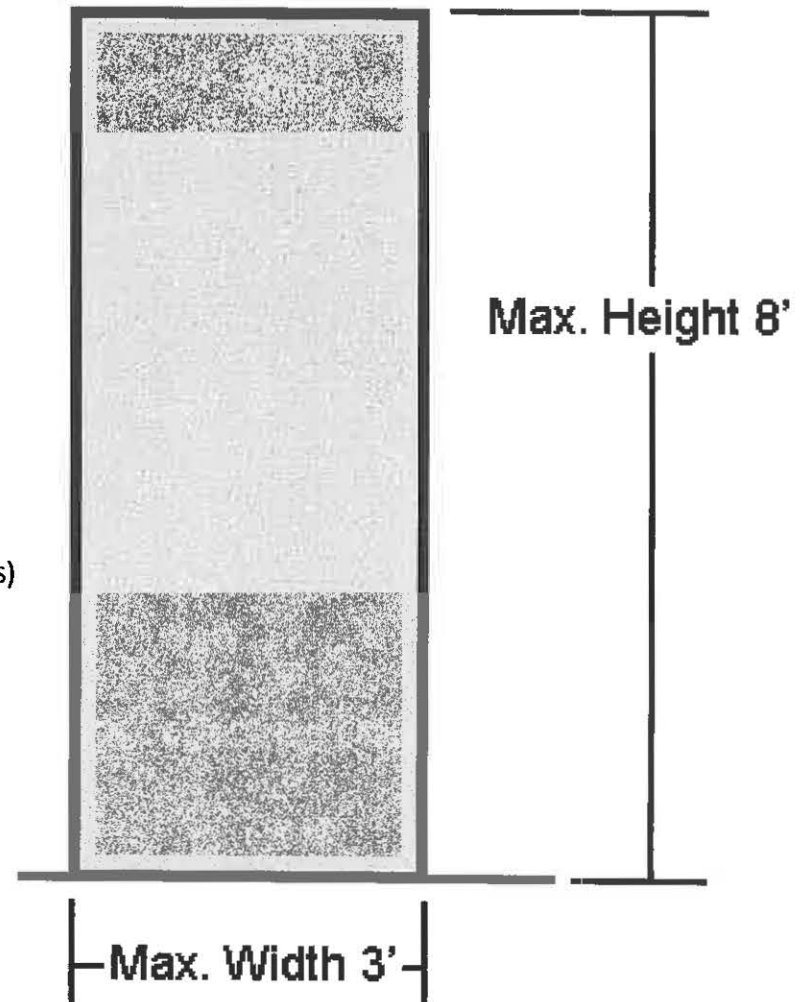

VIII. Vehicular Directional Sign

DIRECTIONAL SIGN TYPE 2

MAX. HEIGHT: 12'

MAX. SIGN AREA: 2 SQ FT PER SIGN FACE

MATERIALS: ALUMINUM BODY (OR SIMILAR)

LIGHTING: MAY CONTAIN LIGHTING ON TOP OF POLE

MINIMUM CLEARANCE: 7'

NOTE: MAY BE PROVIDED TO DIRECT VEHICULAR TRAFFIC (HANDICAPPED ACCESS, DELIVERIES, NO PARKING, BUILDING ENTRIES, ETC.). THESE SIGNS SHALL NOT INCLUDE ANY OCCUPANT NAMES OR LOGOS.

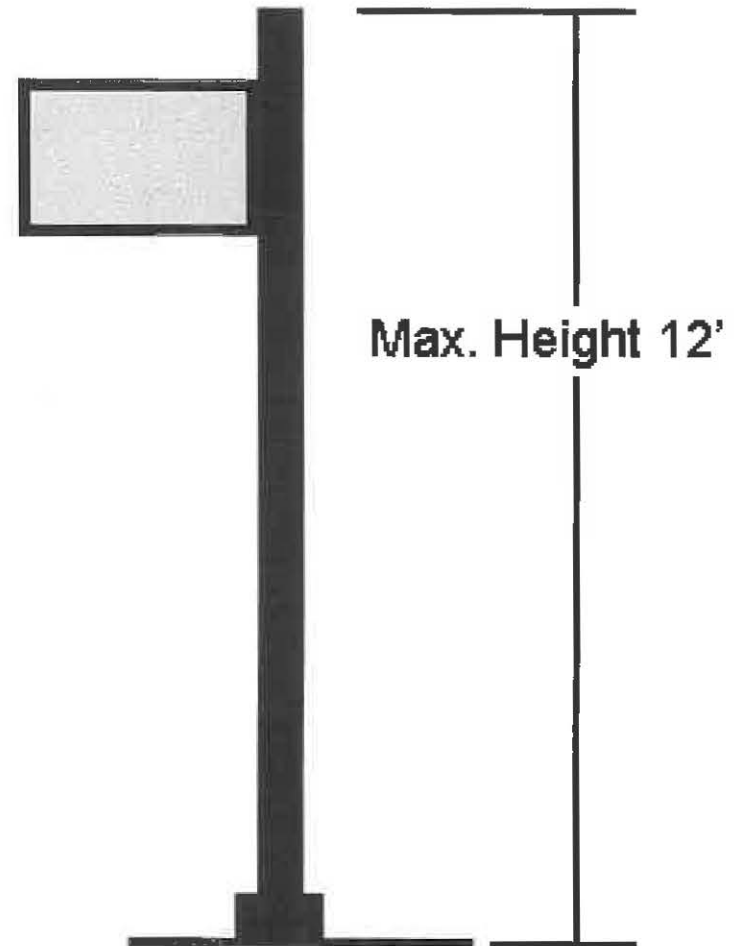

IX. Pole Banners

POLE BANNER SIGNS

MAX. HEIGHT:	12'
MAX SIGN AREA:	18 SQ FT PER SIGN FACE
MATERIALS:	ALUMINUM BODY (OR SIMILAR)
LIGHTING:	MAY CONTAIN LIGHTING ON TOP OF POLE
MINIMUM CLEARANCE:	7'
NOTE:	MAY ONLY CONTAIN EVENT MESSAGES.

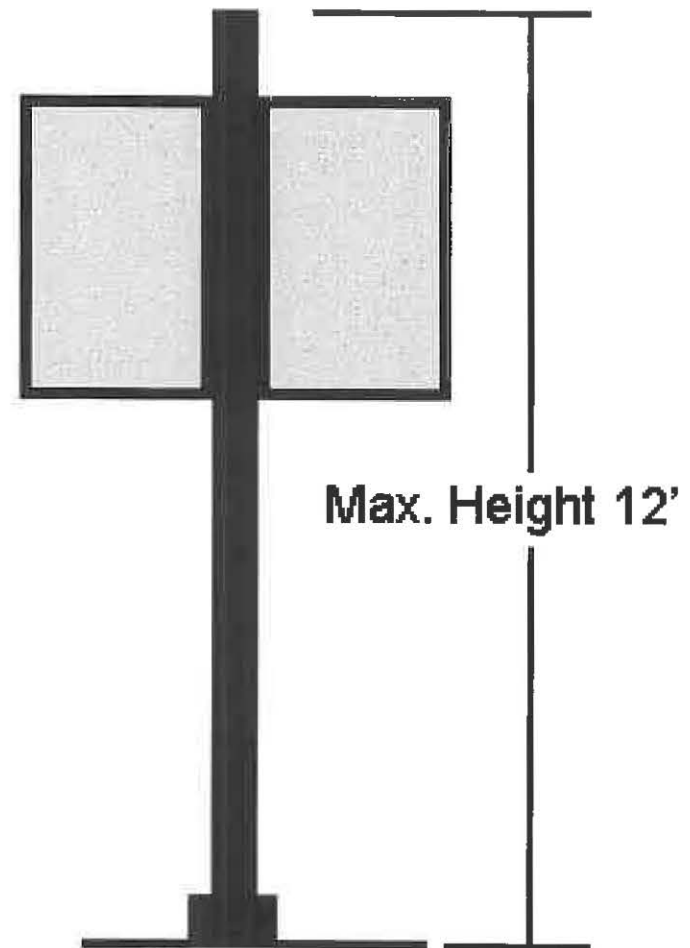

X. Wall Signs

MAXIMUM NUMBER:	EACH OCCUPANT MAY HAVE ON EACH SIDE THAT THE OCCUPANT HAS AN EXTERIOR FAÇADE FACING A PUBLIC STREET, PRIVATE STREET, OR MANEUVERING LANE, UP TO THREE (3) MAX PER OCCUPANT
LOCATION:	WALL SIGNS MAY EXCEED BUILDING ROOF OR PARAPET LINES
MAX. SIGN AREA:	PRIMARY ENTRANCE/EXIT: 1.5 X FAÇADE LENGTH OF THE LEASED SPACE; HOWEVER, WALL SIGNS IN SUBAREAS 2 AND 3 MAY NOT EXCEED 200 SQUARE FEET IN AREA NON-ENTRANCE/EXIT SIDE: 32 SQUARE FEET
PROJECTION:	WALL SIGNS MAY NOT PROJECT MORE THAN 18"
LIGHTING:	MAY BE INTERNALLY OR EXTERNALLY ILLUMINATED

NOTES:

- MAY BE PLACED ONLY ON THE EXTERIOR SURFACE OF THE PRINCIPAL BUILDING, OR PORTION THEREOF, WHICH IS INCLUDED AS PART OF THE OCCUPANT'S INDIVIDUALLY LEASED/OWNED PREMISES;
- SUBORDINATE 'TAG' SIGNS IDENTIFYING CERTAIN FUNCTIONS OR COMPONENTS OF A TENANT'S SALES OR SERVICE, SUCH AS "PHARMACY" OR "GARDEN CENTER," ARE ADDITIONALLY ALLOWED BUT MAY NOT REPEAT THE TENANT'S TRADE NAME AND SHALL COUNT TOWARDS THE OVERALL MAXIMUM SQUARE FOOTAGE.
- AN OCCUPANT WITH INDIVIDUALLY OWNED/LEASED PREMISES THAT DOES NOT INCLUDE PART OF AN EXTERIOR FACADE: ONE SIGN OF UP TO 6 SQ FT OF SIGN AREA ON ONE SIDE OF THE EXTERIOR FAÇADE OF THE PRINCIPAL BUILDING IN WHICH SUCH OCCUPANT IS LOCATED;

XI. Awning, Under-Canopy/Projecting, Blade, and Marquee Signs

AWNING SIGNS

NUMBER AND LOCATION:	ONE (1) PER OCCUPANT FOR EACH SIDE THAT OCCUPANT HAS AN EXTERIOR FAÇADE, UP TO THREE (3) SIDES MAX, THAT FACES A PUBLIC STREET, PRIVATE STREET, OR MANEUVERING LANE. MULTI-TENANT BUILDINGS SHALL BE DEEMED AS ONE SINGLE ENCLOSED BUILDING SO THAT WALL SIGNAGE IS ALLOWED ON EACH SIDE FACING A PUBLIC STREET, PRIVATE STREET, OR MANEUVERING LANE, ON UP TO THREE (3) SIDES.
MIN. PLACEMENT HEIGHT:	8' ABOVE GROUND LEVEL AS MEASURED BY THE AVERAGE GRADE DIRECTLY BELOW THE SIGN
MAX. PLACEMENT HEIGHT:	ROOFLINE, TOP OF PARAPET, OR 18 FEET, WHICHEVER IS LESS
MAX. SIGN AREA:	10 SQUARE FEET MAX WITH 16 INCHES MAX LETTER HEIGHT. WITHIN TOWN CENTER: 8 SQUARE FEET MAX WITH 12 INCHES MAX LETTER HEIGHT
MAX. WALL PROJECTION:	PROPERTY LINE

UNDER-CANOPY OR PROJECTING SIGNS

NUMBER AND LOCATION:	ONE (1) PER OCCUPANT FOR EACH SIDE THAT OCCUPANT HAS AN EXTERIOR FAÇADE, UP TO THREE (3) SIDES MAX, THAT FACES A PUBLIC STREET, PRIVATE STREET, OR MANEUVERING LANE. MULTI-TENANT BUILDINGS SHALL BE DEEMED AS ONE SINGLE ENCLOSED BUILDING SO THAT WALL SIGNAGE IS ALLOWED ON EACH SIDE FACING A PUBLIC STREET, PRIVATE STREET, OR MANEUVERING LANE, ON UP TO THREE (3) SIDES.
MIN. PLACEMENT HEIGHT:	9' ABOVE GROUND LEVEL AS MEASURED BY THE AVERAGE GRADE DIRECTLY BELOW THE SIGN
MAX. PLACEMENT HEIGHT:	ROOFLINE OR TOP OF PARAPET
MAX. SIGN AREA:	15 SQUARE FEET MAX
MAX. WALL PROJECTION:	4' FROM BUILDING FACE

BLADE SIGNS

LOCATION:	ONE (1) MAY BE PLACED AT A BUILDING ENTRANCE OF A THEATER OR HOTEL
MIN. PLACEMENT HEIGHT:	9' ABOVE GROUND LEVEL AS MEASURED BY THE AVERAGE GRADE DIRECTLY BELOW THE SIGN
MAX. PLACEMENT HEIGHT:	4' ABOVE TOP OF PARAPET
MAX. SIGN AREA:	NONE, EXCEPT THAT SIGNAGE MAY NOT EXCEED PERMITTED WALL SIGNAGE MAXIMUMS
MAX. WALL PROJECTION:	PROPERTY LINE
NOTE:	MAY ONLY BE USED WHEN INCLUDED AS PART OF A THEATER OR HOTEL/MOTEL AND MAY ONLY IDENTIFY THE NAME OF THE ESTABLISHMENT.

MARQUEE SIGNS

NOTE:	THREE (3) BUILDING-MOUNTED CABINETS WITH A MAXIMUM OF FIFTY (50) SQUARE FEET EACH ARE ALLOWED FOR THEATERS TO ADVERTISE THE NAME OF THE PLAYS, EVENTS, MOVIES, OR ARTISTS.
-------	--

XII. Pedestrian Signs

PEDESTRIAN SIGNS IN SUBAREAS 2 AND 3. THE FOLLOWING PEDESTRIAN SIGNS ARE PERMITTED WITHIN SUBAREAS 2 AND 3, AND MAY INCLUDE THE BUTLER DEVELOPMENT LOGO AND NAME, OCCUPANT(S) LOGO AND NAME, AND EVENT INFORMATION.

- A. SIGNAGE DISPLAYED ON KIOSK BOOTHS WITH UP TO FOUR (4) SIGN FACES EACH AT A MAXIMUM OF TWENTY (20) SQUARE FEET PER SIGN FACE. SIGNAGE ON KIOSK BOOTHS MAY BE PROVIDED IN A DIGITAL OR ELECTRONIC FORMAT, PROVIDED THAT THE DIGITAL OR ELECTRONIC SIGNS ARE NOT VISIBLE FROM ANY PUBLIC OR PRIVATE STREET OR MANEUVERING LANE.
- B. DIRECTIONAL SIDEWALK SIGNAGE SHALL BE PERMITTED WITH UP TO A MAXIMUM OF TEN (10) SQUARE FEET PER SIGN FACE.
- C. CONCIERGE BOOTHS MAY HAVE A MAXIMUM OF TWELVE (12) SQUARE FEET PER BOOTH.

XIII. Temporary Signs

TEMPORARY SIGNS. TEMPORARY PROJECT, DEVELOPMENT SITE AND/OR BUILDING SIGNS MAY BE PERMITTED ON PARCELS WITHIN THE DEVELOPMENT TO ANNOUNCE COMING STORES, SPECIAL EVENTS, AND GRAND OPENINGS.

- A. PROMOTIONAL BANNER SIGNS ARE PERMITTED AT THE MAJOR ENTRANCES TO THE DEVELOPMENT AND ON OUTPARCELS. THESE TEMPORARY BANNER SIGNS WILL BE PERMITTED NOT TO EXCEED FIFTY (50) SQUARE FEET IN AREA, AND MAY BE DISPLAYED FOR A MAXIMUM OF FOURTEEN (14) DAYS EXCEPT THAT SUCH BANNERS MAY BE DISPLAY FORTY-FIVE (45) DAYS PRIOR TO CHRISTMAS. THE BANNERS SHALL BE ALLOWED TO DISPLAY LOGOS AND/OR THE NAME OF THE PROJECT AND/OR OWNER. THESE SIGNS SHALL NOT COUNT TOWARD THE OVERALL MAXIMUM SIGN AREAS ALLOWABLE FOR MONUMENT OR BUILDING SIGNS.
- B. SEASONAL AND FESTIVAL POLE BANNERS MAY BE PLACED ON THE LIGHT POLES ALONG STREETS WITHIN THE DEVELOPMENT, AND SHALL NOT REQUIRE INDIVIDUAL SIGN PERMITS. DESIGN OF THESE SIGNS SHALL BE CONSISTENT WITH THE HEIGHT AND OTHER STANDARDS DEFINED IN THIS BUTLER DEVELOPMENT MASTER SIGNAGE PLAN.
- C. SIGNS IDENTIFYING THE LOCATION OF CONSTRUCTION ACCESS ROADS MAY BE PLACED ALONG STATE ROAD 24 (ARCHER ROAD), STATE ROAD 121 (SW 34TH STREET), AND SW 24TH AVENUE IN ORDER TO LIMIT THE NUMBER OF CONSTRUCTION ACCESS POINTS. THESE SHALL NOT EXCEED 64 SQUARE FEET EACH.
- D. EACH DEVELOPMENT PARCEL WITHIN THE LARGER DEVELOPMENT SITE MAY HAVE ITS OWN TEMPORARY PROJECT SIGN IDENTIFYING THE TENANT, CONTRACTORS AND CONSULTANTS WORKING ON THAT PARTICULAR PARCEL, NOT TO EXCEED 32 SQUARE FEET EACH. ALL TEMPORARY PROJECT SIGNS PLACED IN CONJUNCTION WITH A DEVELOPMENT SITE MAY BE ERECTED AT THE TIME OF FINAL DEVELOPMENT PLAN APPROVAL, AND MUST BE REMOVED NOT LATER THAN 45 DAYS FROM ISSUANCE OF A CERTIFICATE OF OCCUPANCY FOR THE PARTICULAR DEVELOPMENT.
- E. TEMPORARY WALL SIGNS, SUCH AS BANNERS ANNOUNCING COMING STORES OR GRAND OPENINGS SHALL BE ALLOWED DURING CONSTRUCTION AND INITIAL OPENING, AND SHALL BE REMOVED NOT LATER THAN 45 DAYS FOLLOWING ISSUANCE OF A CERTIFICATE OF OCCUPANCY FOR THE PARTICULAR TENANT, BUSINESS, OR PROJECT.

XIV. Amortization of Existing Signs

AMORTIZATION OF EXISTING SIGNS. EXISTING FREESTANDING SIGNS LAWFULLY PERMITTED PRIOR TO THE ADOPTION OF THE BUTLER DEVELOPMENT PD ORDINANCE NO. 121108 MAY CONTINUE TO EXIST IN GOOD REPAIR AND SIGN FACES, INCLUDING THE OCCUPANT(S) NAMES, MAY BE CHANGED. ALONG ARCHER ROAD, NO NEW OUTPARCEL SIGN OR PROJECT ENTRY SIGN SHALL BE PERMITTED UNTIL THE DEVELOPER IDENTIFIES TO THE CITY THE ONE (1) OR MORE EXISTING FREESTANDING SIGN(S) THAT WILL BE REMOVED UPON CONSTRUCTION OF THE NEW SIGN. THIS PROVISION WILL REMAIN EFFECTIVE UNTIL SUCH TIME AS ALL FREESTANDING SIGNS LAWFULLY PERMITTED PRIOR TO THE ADOPTION OF THE BUTLER DEVELOPMENT PD ORDINANCE NO. 121108 HAVE BEEN REMOVED.