

Agenda Item 090588
Regional Utilities Committee



ConnectFree Program

May 20, 2014

Outline

- ConnectFree Resolution Overview
- Source of Funds
- How Funds are Being Used
- Current Status
- Questions for Consideration by RUC

ConnectFree Resolution Overview

- Passed July 2003; Revised November 2005; Revised January 2014
- ½ of proceeds from surcharge on W/WW connection charges outside City go to General Government ConnectFree fund
- Extension of Water, WW & Reclaimed water to residences inside City
- Prioritization

Source of Funds: Surcharge on W/WW Connection Charges Outside City

Connection Charge for 5/8" meter outside City limits

| | <u>Connect Charge</u> | <u>25% Surcharge</u> |
|--------------|-----------------------|----------------------|
| Water | \$1,550 | \$387.50 |
| Wastewater | \$3,680 | \$920.00 |
| Total | \$5,230 | \$1,307.50 |

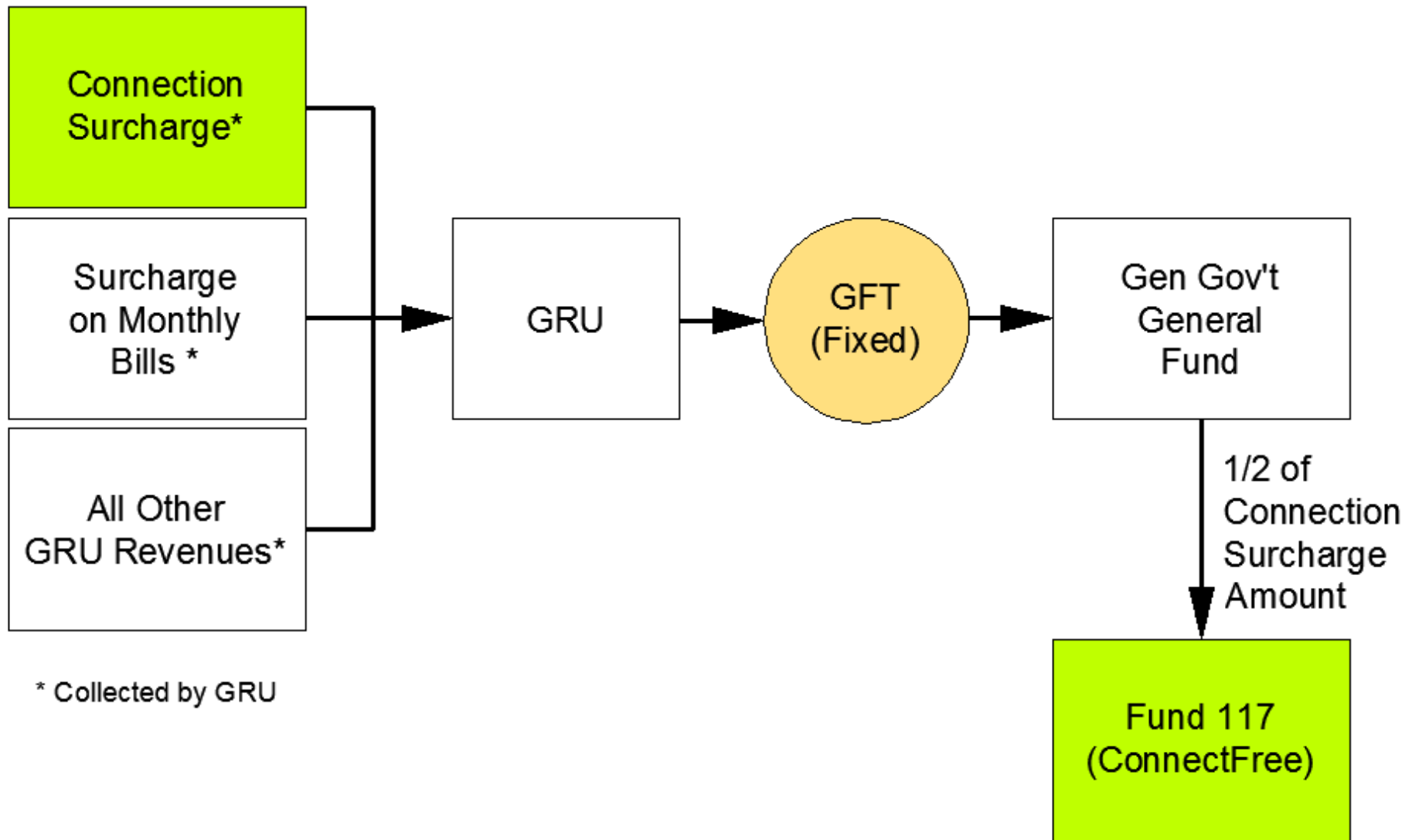

Connection Surcharge :
Flow of Funds Under Current GFT System

Total Water + WW Surcharge Revenue

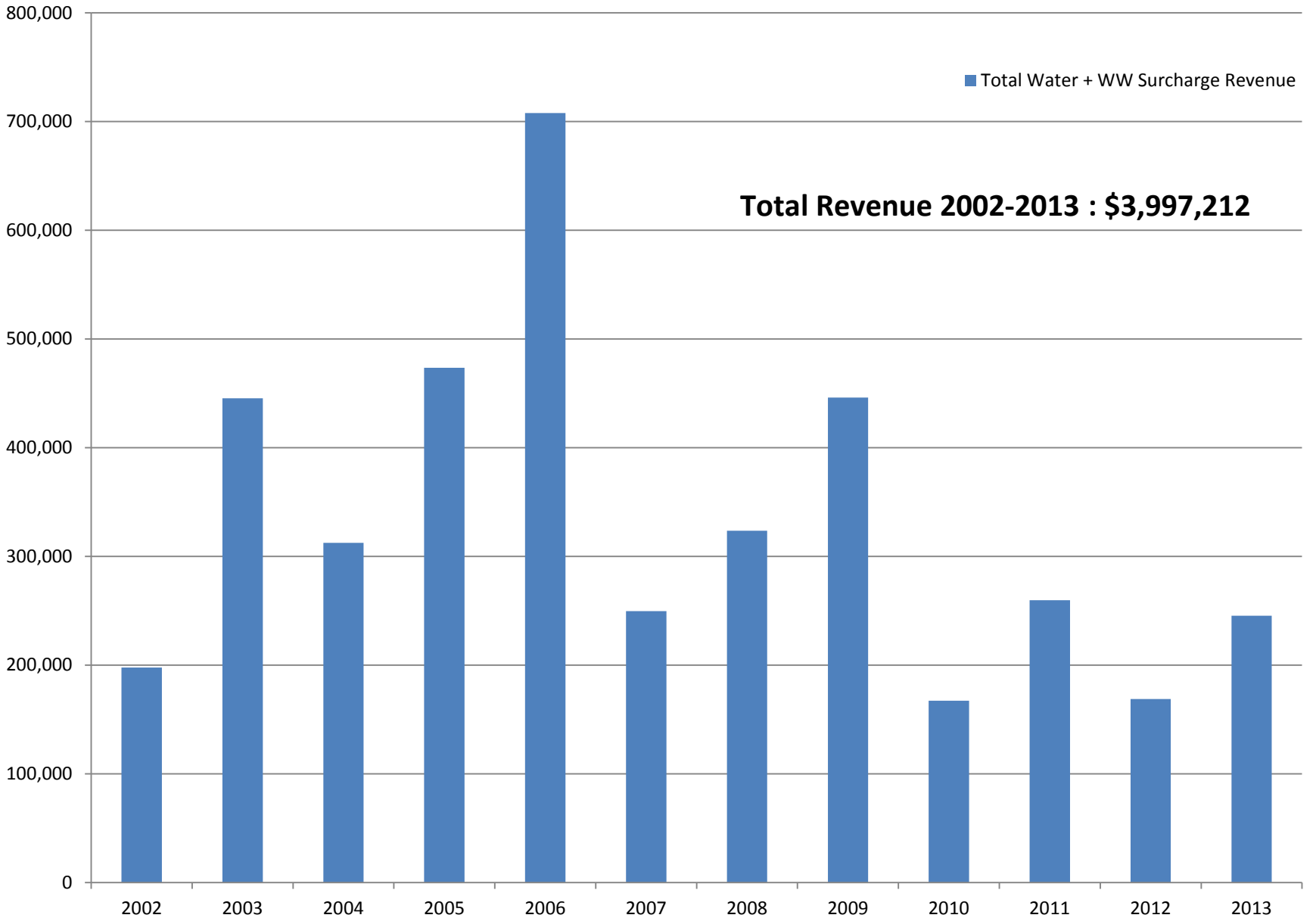

ConnectFree Revenue and Expenditures to Date

Total Revenue* \$1,848,469

Total Spent \$ 551,312

Total Fund Balance \$1,297,469

*Surcharge collection started in 2002. Allocation of ½ of surcharge revenue to ConnectFree started in 2004. Revenue shown here is from 2004 through 2014.

How Funds Are Being Used

- Fund Allocation (per Resolution)
 - 60% Programmed Extensions
 - Marketing to residents based on prioritization
 - 20% Health/Safety/Environment*
 - Cases with health/environmental concern
 - 20% Affordable Housing*
 - New & existing affordable housing projects

**Funds not encumbered roll over to Programmed Extension fund each year*

Implementation

- Joint GRU/General Government Team
 - W/WW Planning
 - W/WW Engineering
 - Community Relations
 - New Services
 - Housing & Community Development
 - City Managers Office
 - Public Works

Implementation

- Implementation based on prioritization
 - Emphasis on low income areas
 - Door to door marketing in CDBG areas
 - Referrals from GRU new services, housing division, health dept & others
 - Public outreach
 - Plumbing improvements paid for low income & for CDBG areas

Resolution Exclusions

- Not available to residents outside City limits
- Non-residential limited to facilities owned & operated by non-profit or government for charitable service to at-risk or special needs populations, & subject to approval by City Commission

Current Status

- 64 Customers served to date
 - All 64 received water, 2 of them received WW service
- Water available throughout City limits
 - City's cost for extension limited to \$7,500 per lot
 - On-site plumbing paid for low income customers & customers in CDBG

Current Status

- Wastewater available where service can be provided by gravity
 - Requires engineering evaluation to determine if feasible
 - City's cost for extension limited to \$15,000 per lot
 - On-site plumbing paid for low income customers & customers in CDBG

2014 & Projected 2015 ConnectFree Balances

| | |
|---|------------------|
| Total Fund Balance | \$1,297,469 |
| Empowerment Homeless Center | - \$625,000 |
| Arbour Valley Affordable Housing Project | - \$46,000 |
| Reichert House | - \$10,000 |
| 2014 Net Available Balance | \$616,469 |
| Allocation of ½ of 2014 W/WW Surcharge Rev | \$125,000 |
| Other ConnectFree Projects (approximate) | -\$80,000 |
| Projected 2015 Net Available Balance | \$661,469 |

Alternatives Moving Forward

1. Continue program as-is
2. Expand program
 - County residents
 - Non-profits
 - Commercial customers

Alternatives Moving Forward

3. Use existing available balance &/or future revenues to mitigate 2015 GRU rates or General Government shortfalls
4. Use 2014 available balance to mitigate GRU W/WW rates, and use future revenues for General Government designated programs