

BICYCLE PARKING FACILITIES

1. 981014

The following bicycle parking racks have been chosen by the City of Gainesville for their durability, security, ease of use, attractiveness, adaptability to different styles of bicycles and lock types, and minimal hazard to pedestrians.

1) **INVERTED-U DISTRIBUTORS**

Ke Hitch
Gainesville, Florida
(352)336-1288

Gainesville Ironworks Supply, Inc.
Gainesville, Florida
(352)375-8402

Contract Connections, Inc.
Model: Wabash Valley 36" Bike Loop
Atlantic Beach, Florida
1-800-772-8369

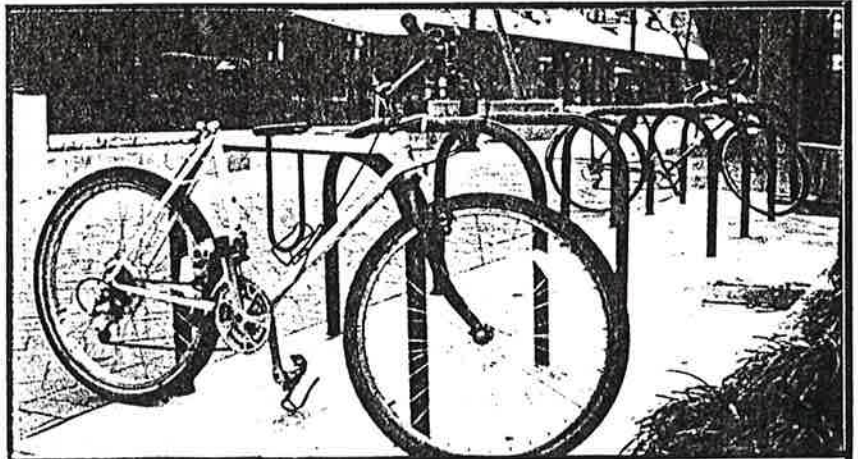

INVERTED-U RACKS AT THE HIPPODROME THEATER

2) **WAVE RACK DISTRIBUTORS**

Brandir, Inc. (Model: Ribbon Rack)
New York, New York
(212)505-6500

Columbia Cascade Co. (Model: Cycloops)
Portland, Oregon
(503)223-1157

Gametime, Inc. (Model: Loop Bike Rack)
Longwood, Florida
1-800-432-0162

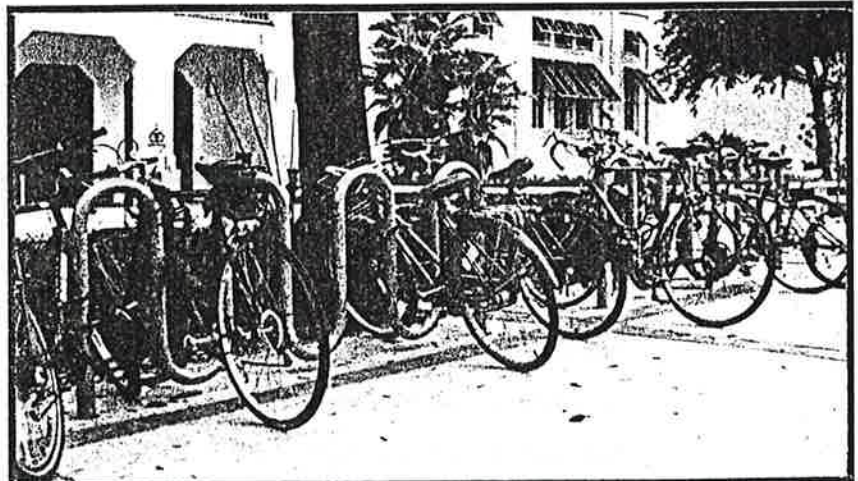

WAVE RACK AT THE ALACHUA COUNTY MAIN LIBRARY

3) **STORAGE LOCKER DISTRIBUTORS**

Lokr, Ltd.
Joplin, Missouri
1-800-245-3565

Cycle-Safe, Inc.
Grand Rapids, Michigan
(616)954-9977

JG Wilson Corp.
Brooklyn, NY
(718)369-2925

Vara Bicycle Parking Systems
Orlando, FL
1-800-354-8624

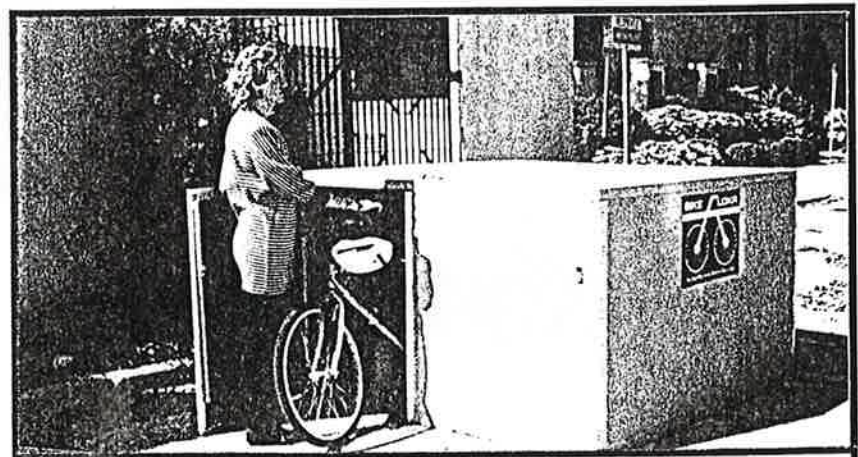

BICYCLE STORAGE LOCKER AT THE THOMAS CENTER

This listing of distributors does not constitute an endorsement by the City of Gainesville. Any company wishing to be added to this list may call the Bicycle/Pedestrian Program at 334-2107.

RESOLUTION NO. R-81-100

PASSED November 2, 1981

A RESOLUTION ADOPTING AN APPROVED LIST OF BICYCLE PARKING DEVICES FOR REQUIRED BICYCLE PARKING FACILITIES PURSUANT TO SECTION 29A-96(a), ZONING CODE OF THE CITY OF GAINESVILLE; PROVIDING AN EFFECTIVE DATE.

WHEREAS, on October 26, 1981, the City of Gainesville adopted Ordinance No. 2650, the same being a new zoning code; and

WHEREAS, Section 29A-96(a) of the Zoning Code of the City of Gainesville requires the City Commission to adopt an approved list of bicycle parking devices for required bicycle facilities;

NOW, THEREFORE, BE IT RESOLVED BY THE CITY COMMISSION OF THE CITY OF GAINESVILLE, FLORIDA:

Section 1. The City Commission of the City of Gainesville hereby adopts and approves the "List of Bicycle Parking Devices," in accordance with the provisions of Section 29A-96(a), Zoning Code of the City of Gainesville, a copy of which is attached to and made a part hereof as if set forth in full.

Section 2. This resolution shall become effective immediately upon adoption.

DATED this 2nd day of November, 1981.



MAYOR COMMISSIONER

ATTEST:

CLERK OF THE COMMISSION

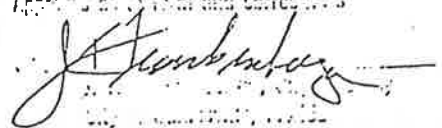
OCT 29 1981

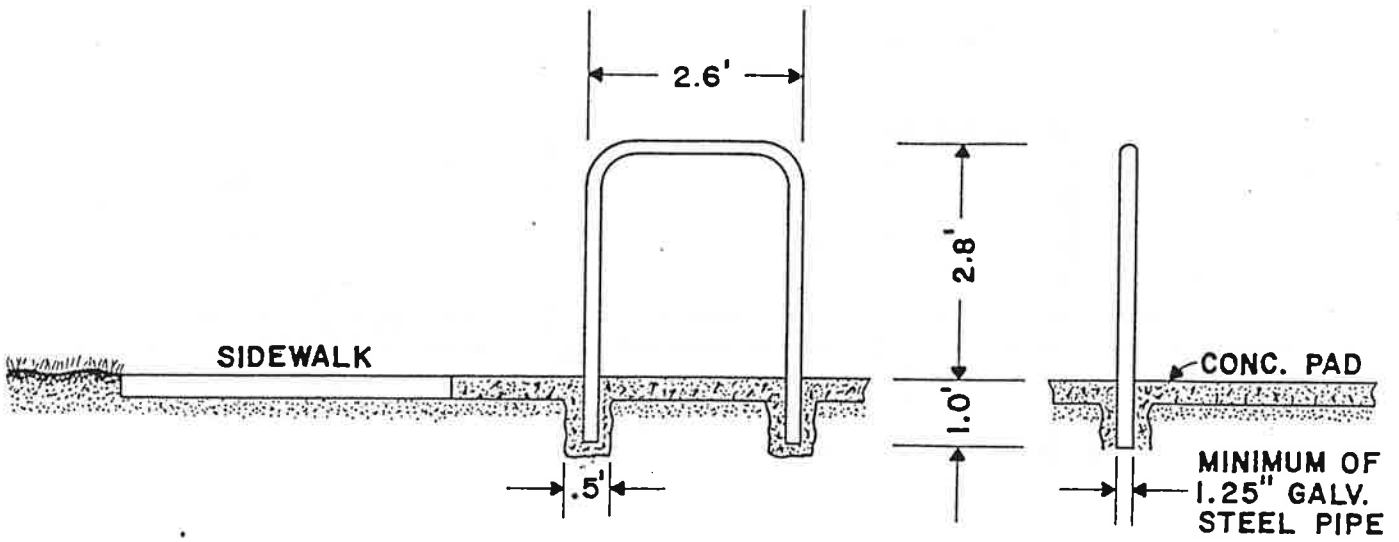
Approved as to form and correctness



ELEVATION

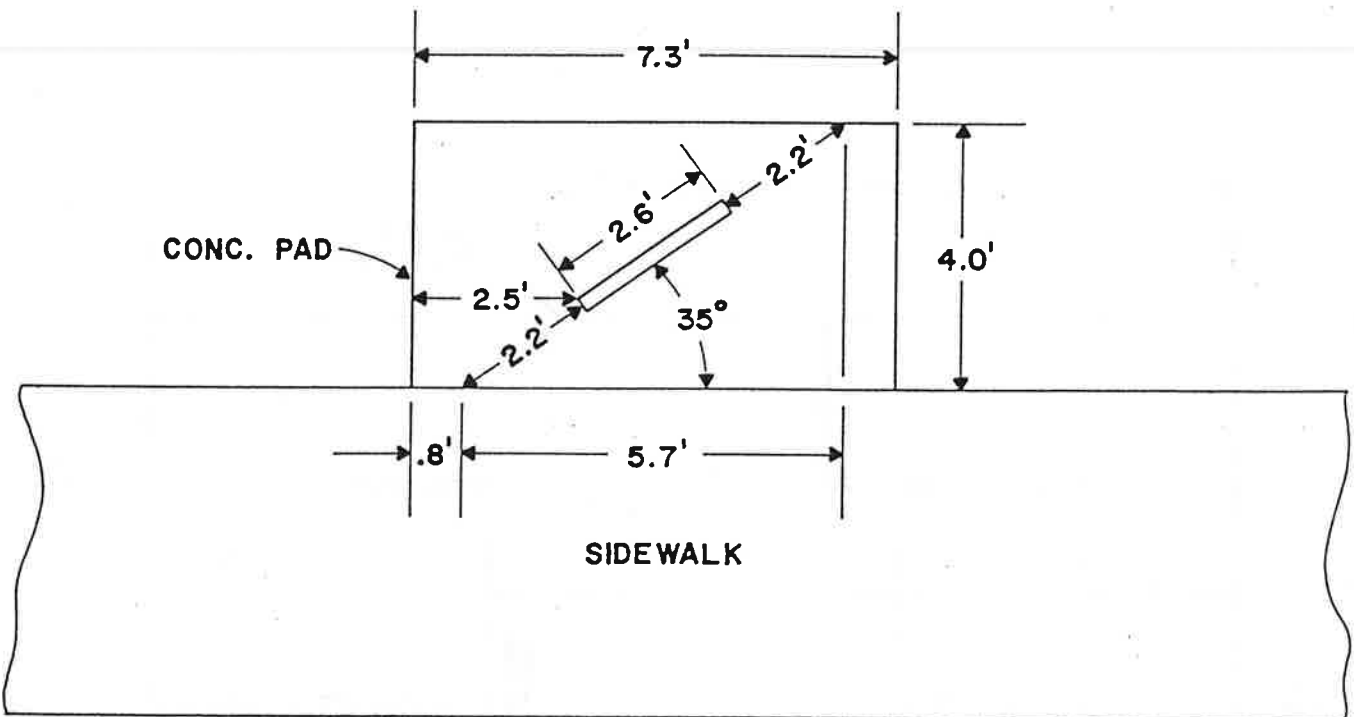

PLAN VIEW

DATE

13 JULY 93

BIKE RACK
STANDARD ANGLED INSTALLATION

SCALE

1" = 3'

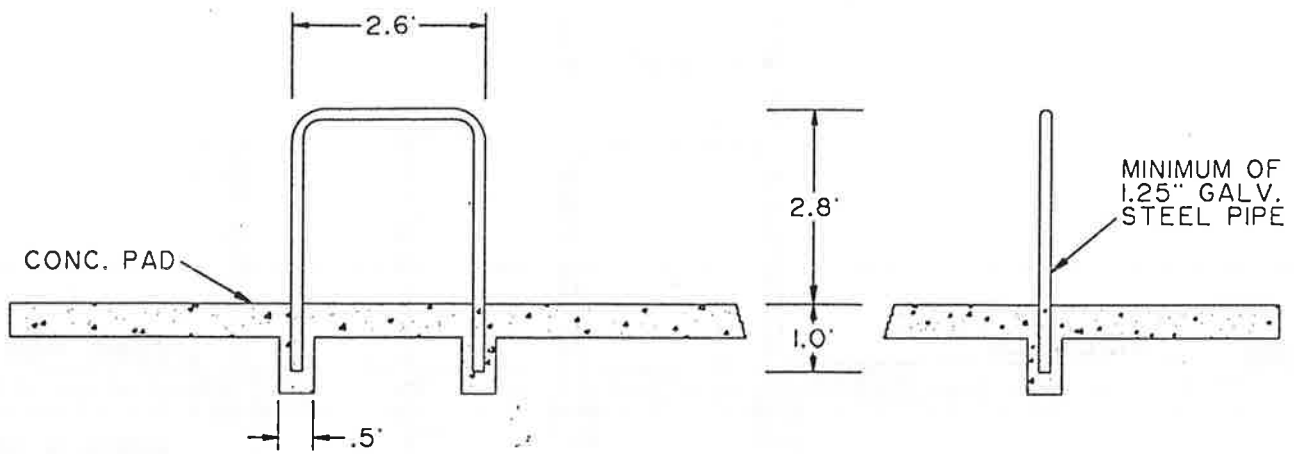

ELEVATION

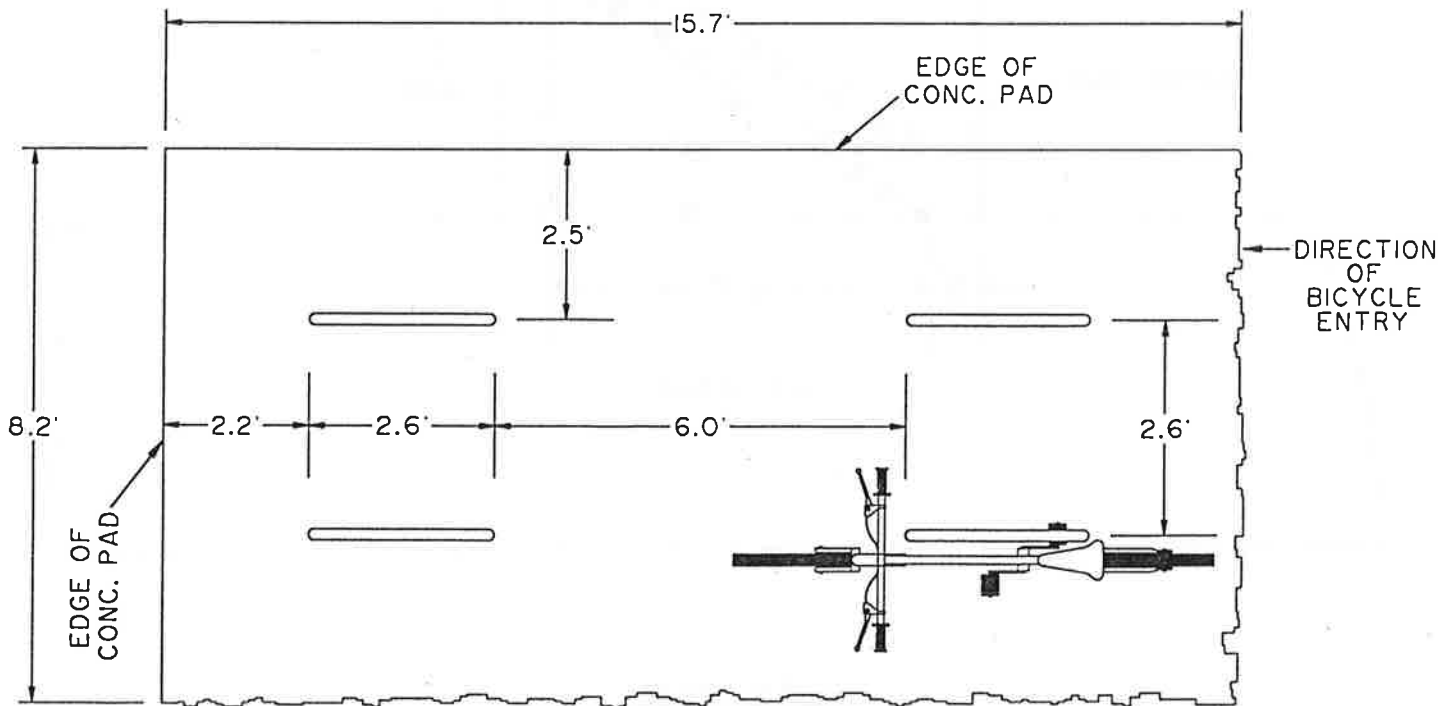

PLAN VIEW

WAVE RACK

NOTE: FT.IN.
CM.

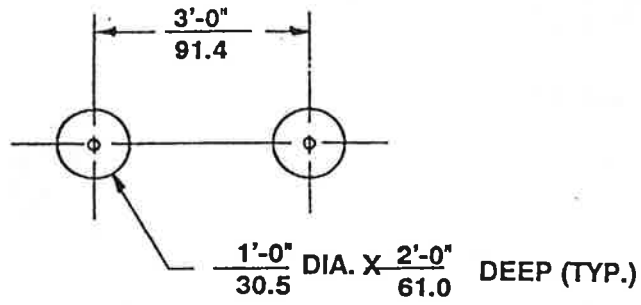

7703
GROUND PLAN

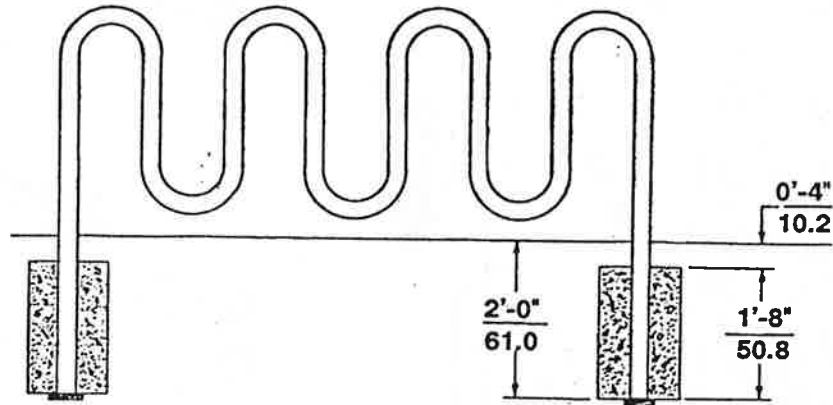

ELEVATION

The "Ribbon Rack"TM should be installed in the following manner:

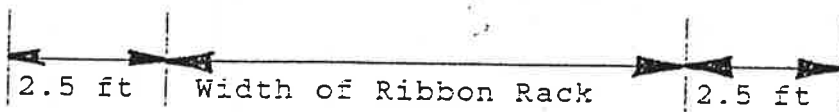
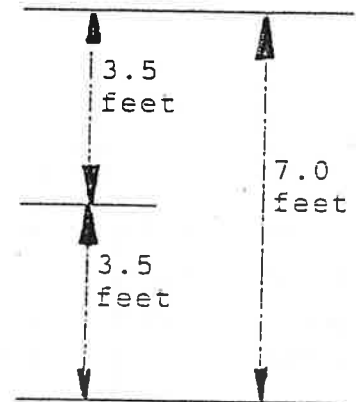
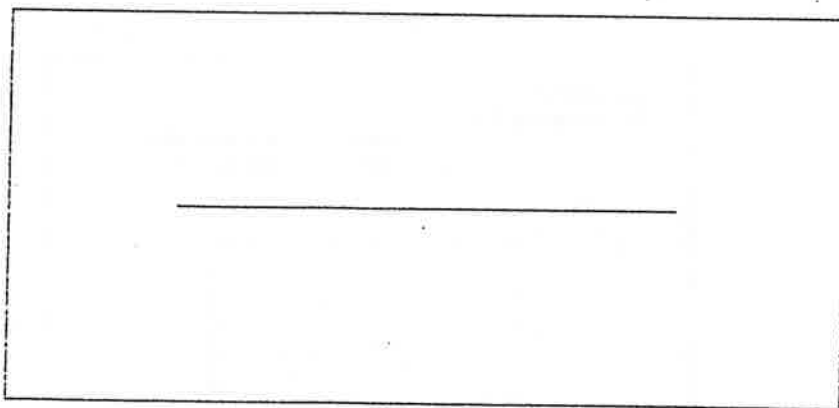

STORAGE LOCKER

The cycle-safe Advantage

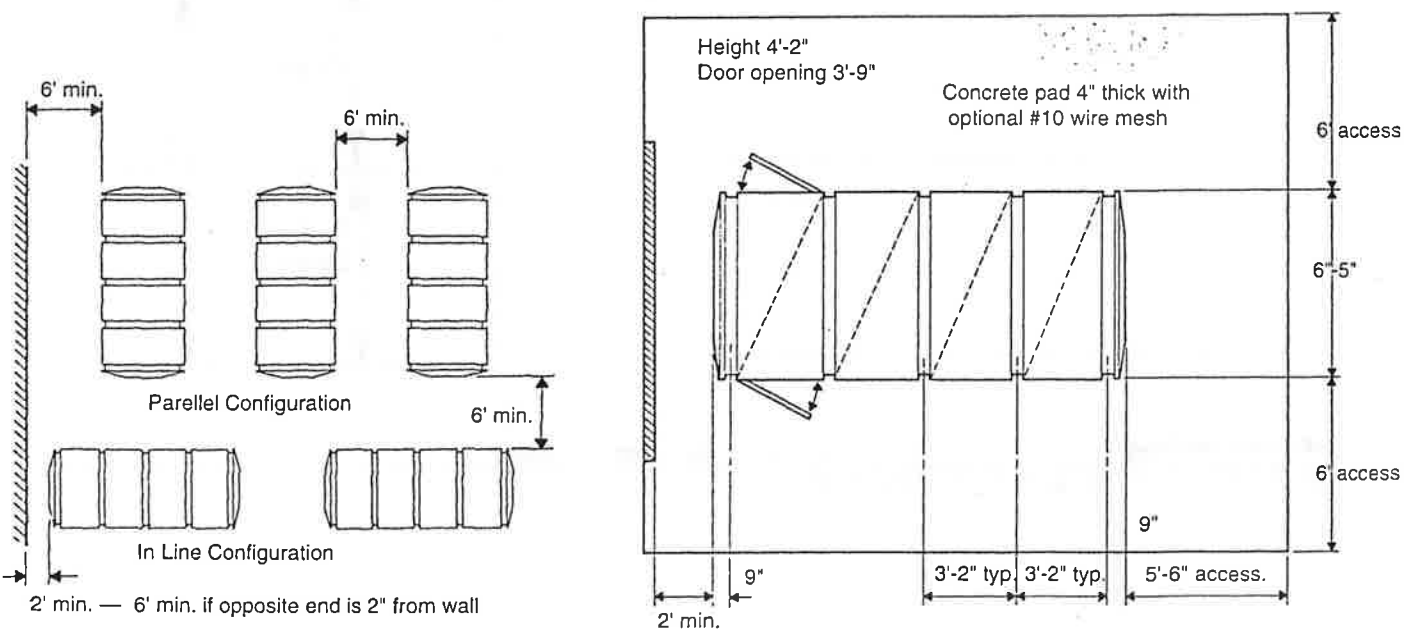
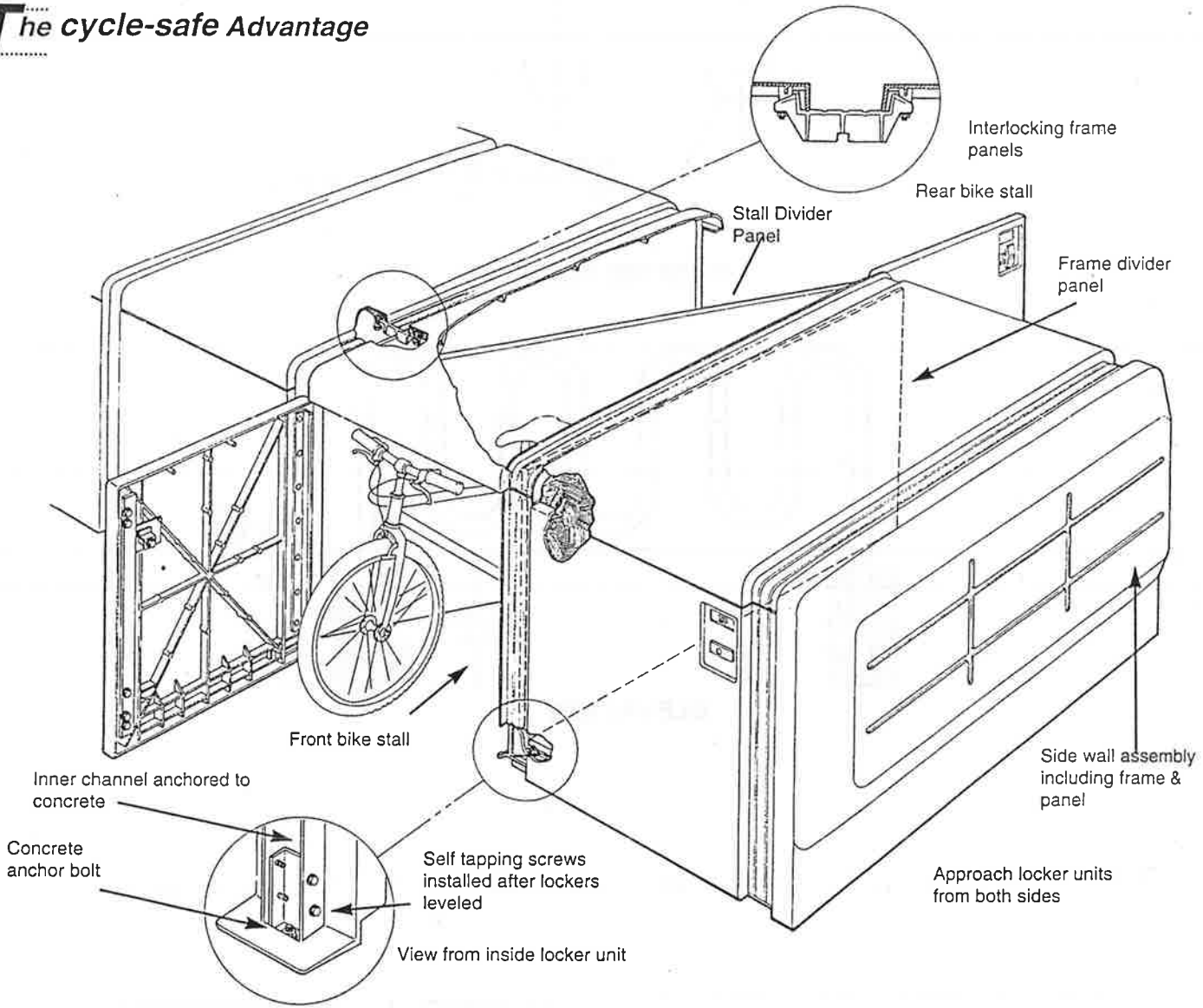

One acre will park 100 cars or 1,340 bicycles individually at one per compartment