

Please make POs and contracts out to:
 Rep Services, Inc.
 902 Waterway Place
 Longwood, FL 32750-3573

 Please mail checks to:
 Rep Services, Inc.
 902 Waterway Place
 Longwood, FL 32750-3573

Quoted To: Gainesville Community Redevelopment Agency 300 E University Avenue Suite 240 Gainesville, FL 32602	Ship To: Gainesville Community Redevelopment Agency Public Works Department City of Gainesville 405 NW 39th Avenue Bldg "L" Gainesville, FL 32609	Bill To: City of Gainesville PO Box 490 Gainesville, FL 32602
Attn: Matthew Dube	Attn: Matthew Dube	Attn: Accounts Payable
Phone: 352-334-2205	Phone: 352-334-2205	Phone: 352-334-5021
Fax: 352-334-2132	Fax: 352-334-2132	Fax: 352-334-3163
	Shipping: Best Way	Terms: Net 30 With CREDIT APPROVAL
	Freight: Prepaid	
	FOB: Destination	

Proposal No: 28331	Project ID: 3216	Option: A	Revision: 1
Proposal Dated: 7/10/2007	Project Name: University Avenue Improvements		
Proposal Expires: 8/9/2007	Project Drawing No: Site Furnishings		
For Questions Call: Sophia Gallegos	Project Contact: Matthew Dube		
Sales Rep: Jim Sims	Project Location: 300 E University Avenue Suite 240 Gainesville, FL 32602		Input By: SG
E-Mail: jsims@repservices.com			

Class	Part No.	Qty	Description	Discount	Unit Wt	Unit Price	Ext. Weight	Ext. Price
Du Mor								
Benches	58-60	13	6' CAST BENCH, STEEL SEAT		296	\$899.00	3,848	\$11,687.00
Receptacles	114-00	2	STEEL PLANTER		96	\$560.00	196	\$1,120.00
	84-32	60	32-GALLON ALL-STEEL RECEPTACLE		175	\$672.00	10,500	\$40,320.00
Subtotal	Du Mor						14,544	\$53,127.00
							Equipment Subtotal:	\$53,127.00
							Freight Charge:	\$2,613.96
							Grand Total:	\$55,740.96

Notes: This proposal is for material, freight and applicable tax only. SITE PREPARATION, UNLOADING, ASSEMBLY, INSTALLATION, AND SURFACING - BY OTHERS. (THE DRIVER WILL NOT UNLOAD THIS SHIPMENT, SO PURCHASER IS REQUIRED TO MAKE ARRANGEMENTS FOR UNLOADING.)

CURRENT ECONOMIC CONDITIONS RELATED TO FUEL COSTS ARE VOLATILE AND ARE AFFECTING FREIGHT COSTS. BE SURE TO PLACE YOUR ORDER BEFORE THE EXPIRATION DATE SHOWN ABOVE TO SECURE THE PRICES ON THIS PROPOSAL.

ORDERS PLACED BASED ON THIS PROPOSAL ARE SUBJECT TO SHIP WITHIN MANUFACTURER'S STANDARD LEAD TIME. REQUESTS FOR EXTENDED SHIPPING TIMES MAY RESULT IN ADDITIONAL COSTS, SUCH AS FREIGHT INCREASES, RAW MATERIAL COST INCREASES, ETC.

Color Selection: BLACK PC FOR ALL

Shipping Notes: FREIGHT COMPANY MUST CALL 48 HOURS PRIOR TO DELIVERY: Matthew Dube 352-334-2205

To order, please sign below and return to Rep Services Inc. at the address or fax number noted below. Thank You.

Name	Date

 0
7
0
5
5
7

We are pleased to provide you with this proposal. **ALL PO'S AND CONTRACTS SHOULD BE SUBMITTED AS NOTED IN THE HEADER!**

If you have any questions, please contact us at:

REP SERVICES, INC. · 902 Waterway Place · Longwood, FL 32750-3573 · 407.831.9658 (P) · 407.834.5366 (F)

800.992.5357 · Offices Statewide · www.repservices.com

model no:

BL100N, BL101N, BL105N
BL106N

BIKE RACKS

36" BIKE LOOP & CARROUSEL BIKE RACK
INGROUND AND SURFACE MOUNT



© Wabash Valley Manufacturing, Inc.

customer service:

ASSEMBLERS: If you find any parts missing or damaged, or if you're having difficulty assembling your furniture/equipment, call us at:

* Before calling, have your product model number available.

1-800-253-8619 (Inside U.S.A.)

260-352-2102 (Outside U.S.A.)

Monday thru Friday,
8:00 AM - 4:30 PM Eastern Time
(EXCEPT HOLIDAYS)

Any correspondence concerning our product should be sent directly to our Customer Service Manager at:

Wabash Valley Manufacturing, Inc.
505 E. Main Street
P.O.Box 5
Silver Lake, IN 46982 U.S.A.
FAX: 260-352-2160

maintenance:

Regular inspection and maintenance of all parts, and fasteners is necessary. Tighten all bolts and nuts. Inspect Tops, Seats, Legs, Braces and Fasteners periodically for wear or vandalism. Replace broken or worn parts immediately or take equipment out of service until repairs are made. Use genuine Wabash Valley replacement parts.

To restore plastisol coating to its luster after prolonged use, wash/rinse/dry and use Armor-All ® or similar quality vinyl protectant.

KEEP THIS ASSEMBLY/SPECIFICATION SHEET FOR FUTURE REFERENCE.

specifications:

NOTE: We reserve the right to change specifications without notice.

Heat fused poly-vinyl coating, finished on inner-metal structure, to an approximate 3/16" thickness.

Framework assemblies are finished with powder coating; electrostatically applied and oven cured according to powder manufacturer's specifications. Fasteners are stainless steel to resist corrosion.

FRAME:

Bike loops consist of 1/2" x 1 1/2" steel flat bar. The inground bike loops use a 5/16" diameter rod, to add support towards the bottom ends. The carousel bike rack uses 2 7/8" galvanized tube with 5/8-11-UNC stud welded to 1/4" plate welded into frame tube. The surface mount base plate consists of 3/8" plate.

CARROUSEL:

Carousel is made of 10 gage sheet metal and 1/2" diameter rod and held onto the frame with a cast aluminum nut.

GENERAL:

Ground space requirements for bike loop are 1 3/4" x 25 7/8". For carousel bike rack ground space requirements are 35 1/2" x 14 1/2" diameter.

parts identification:

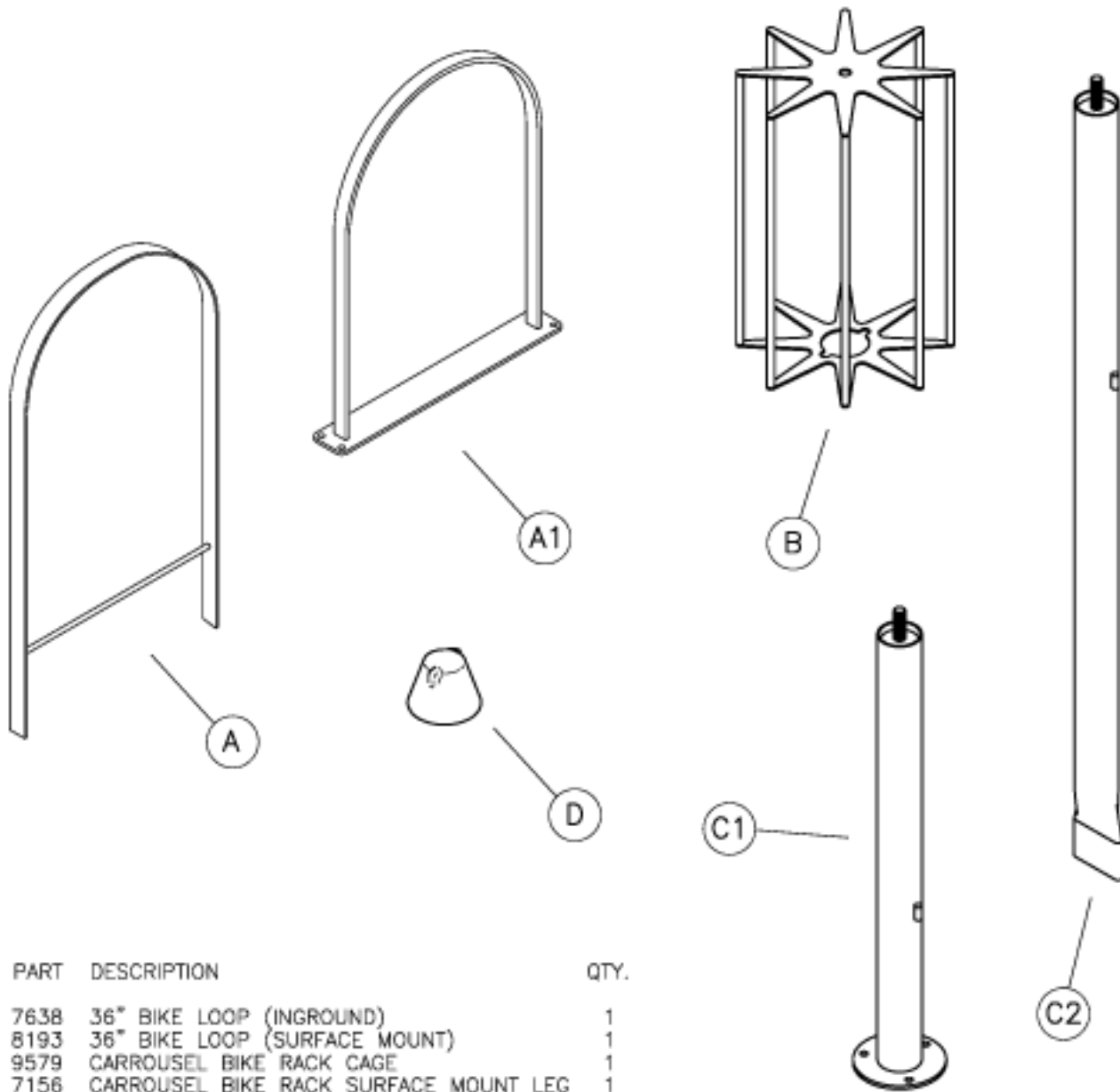

ITEM	PART	DESCRIPTION	QTY.
A	7638	36" BIKE LOOP (INGROUND)	1
A1	8193	36" BIKE LOOP (SURFACE MOUNT)	1
B	9579	CARROUSEL BIKE RACK CAGE	1
C1	7156	CARROUSEL BIKE RACK SURFACE MOUNT LEG	1
C2	7157	CARROUSEL BIKE RACK INGROUND LEG	1
D	7158	CAST NUT	1

hardware identification:

0
7
0
5
5
7

product dimensions:

36" BIKE LOOP – Inground

STEP 1

Prepare two foundation holes as shown below.

STEP 2

Place the bike loop in its foundation holes and block as shown in FIG. 1.

Before pouring concrete, make sure the bike loop holds 36" to the top of the bike loop and is level horizontally as well as vertically.

Pour concrete and let cure for 48 hours.

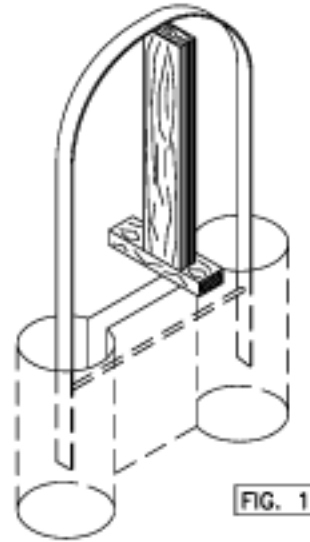

36" BIKE LOOP – Surface Mount

STEP 1

For the surface mount bike rack, determine location and using holes in base plate as a template, drill holes and secure in concrete. See FIG. 2.

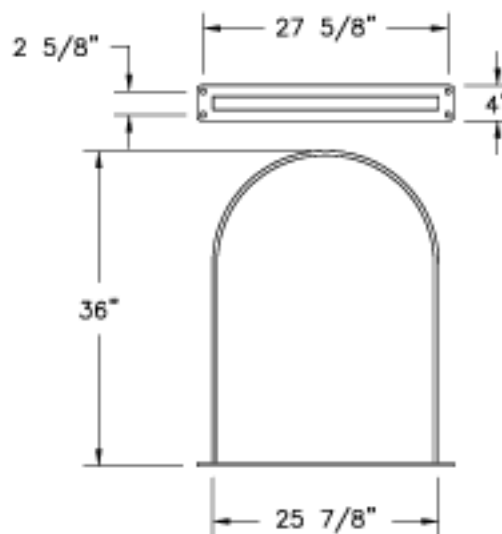
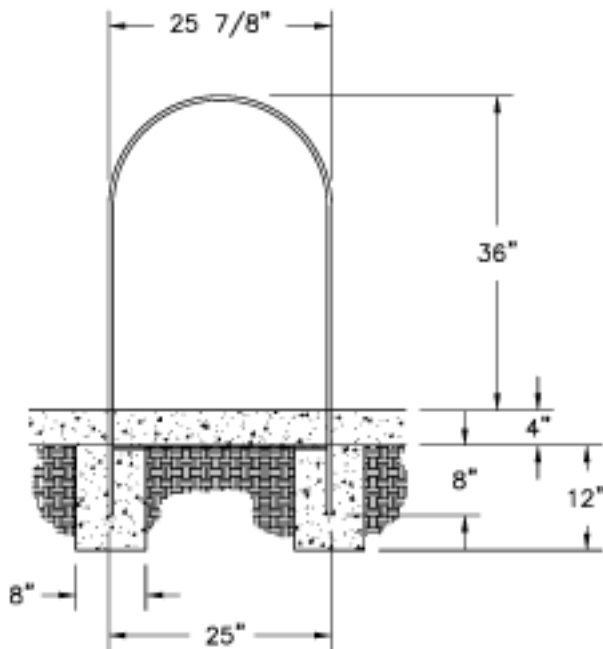
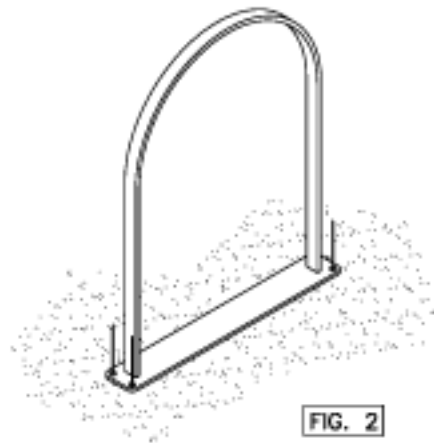

0
7
0
5
5
7

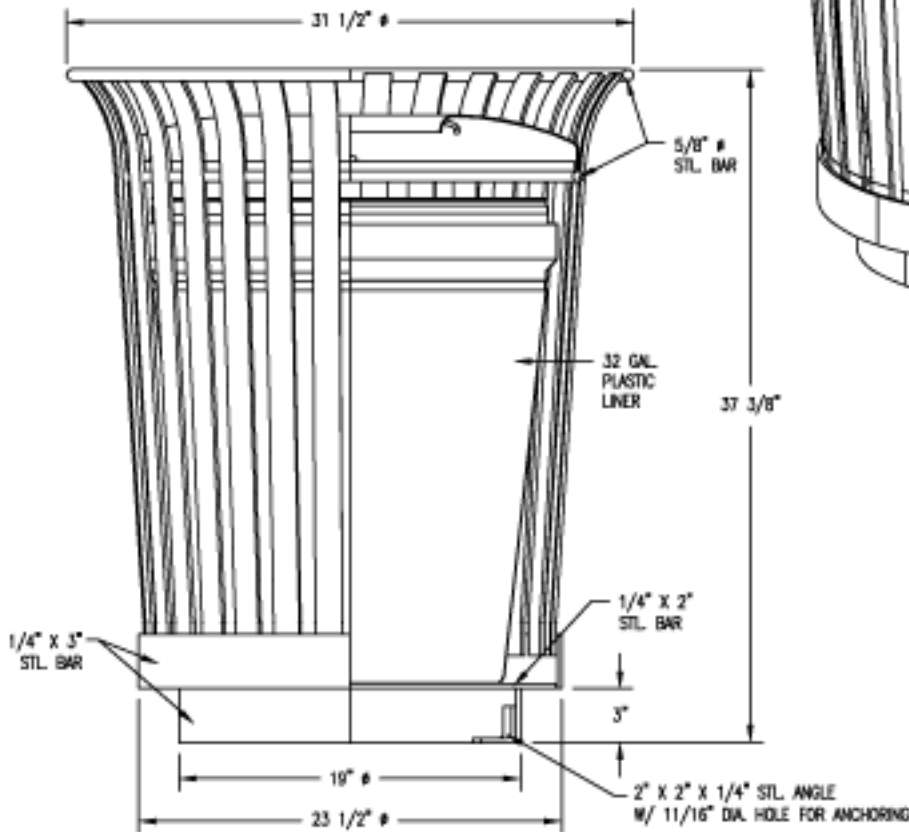
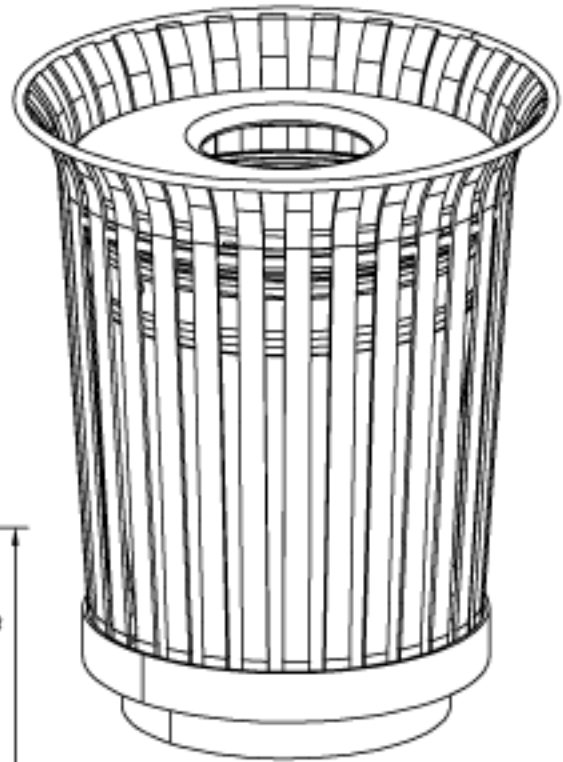
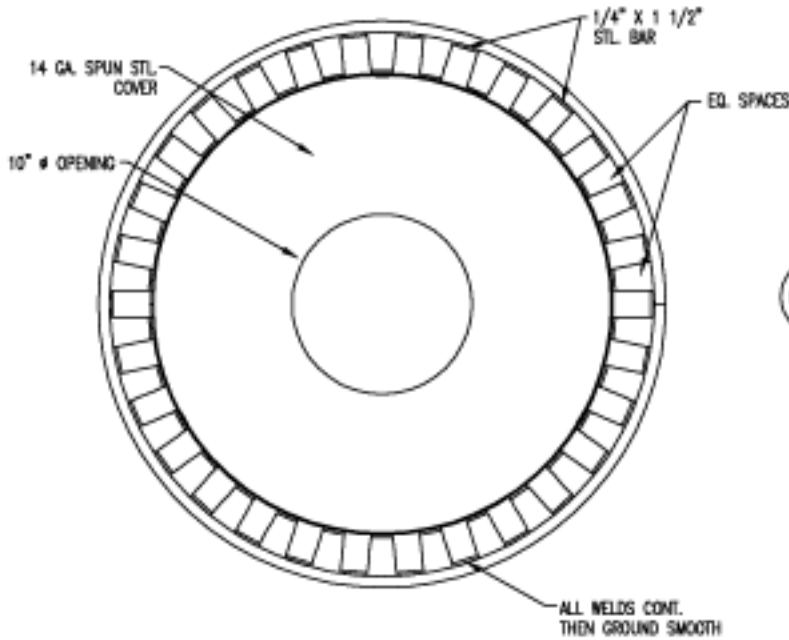

NOTES:

- 1.) ALL STL. MEMBERS COATED W/ ZINC RICH EPOXY THEN FINISHED W/ POLYESTER POWDER COATING.
- 2.) 1/2" X 3 3/4" EXPANSION ANCHOR BOLTS PROVIDED.
- 3.) ALL WELDS CONT. THEN GROUND SMOOTH.
- 4.) RECEPTACLE FULLY ASSEMBLED AT FACTORY.

0
7
0
5
5
7

DuMor, inc.
P.O. Box 142 Mifflintown, PA 17059-0142

SCALE : NONE
DATE DRAWN : 12/12/96
DRAWN BY : AH
DATE REV. : 12/27/06
REV. BY : AMH

TITLE : RECEPTACLE
REV. F
DRAWING NUMBER 84-32-FTO

SHEET 1 OF 2

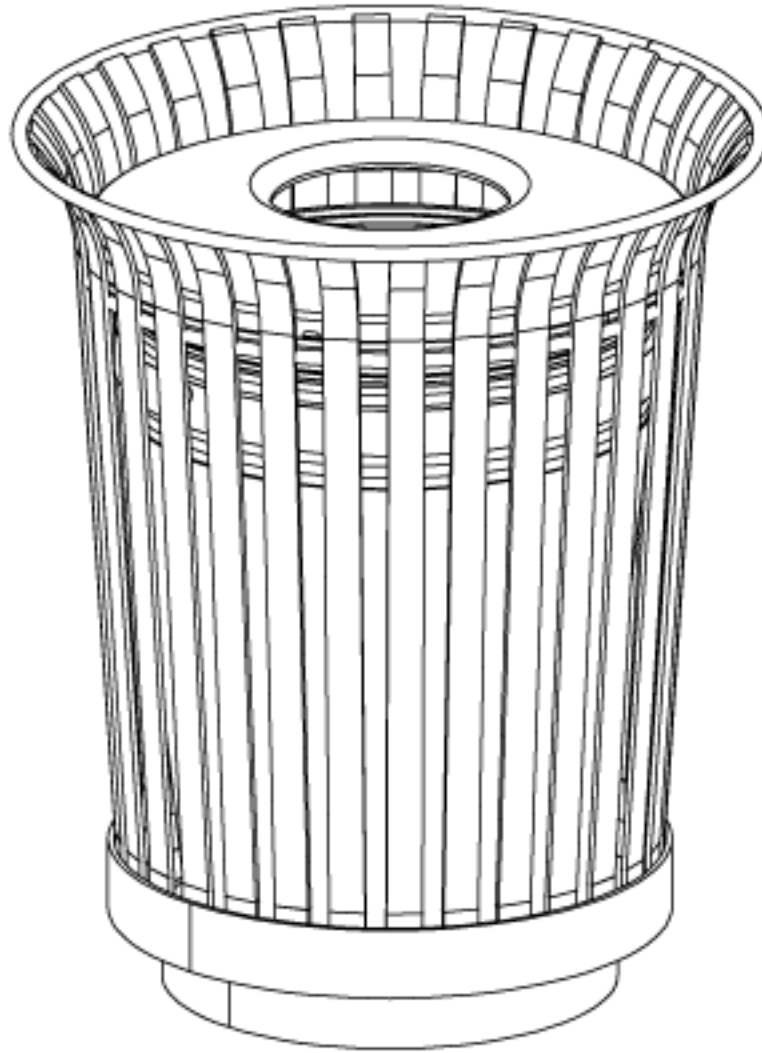

NOTE:

- 1.) RECEPTACLE SHIPPED FULLY ASSEMBLED.
- 2.) COVER ATTACHED W/ 1/8" VINYL COATED CABLE.
- 3.) MOUNT AND ANCHOR AS SPECIFIED.

0
7
0
5
5
7

 DuMor, inc. P.O. Box 142 Mifflintown, PA 17059-0142	SCALE :	NONE	TITLE :	RECEPTACLE ASSEMBLY	
	DATE DRAWN :	1/3/00	REV.	DRAWING NUMBER	84-32-FTO
	DRAWN BY :	JSB	F		
	DATE REV. :	12/27/06			
	REV. BY :	AWH			2 OF 2

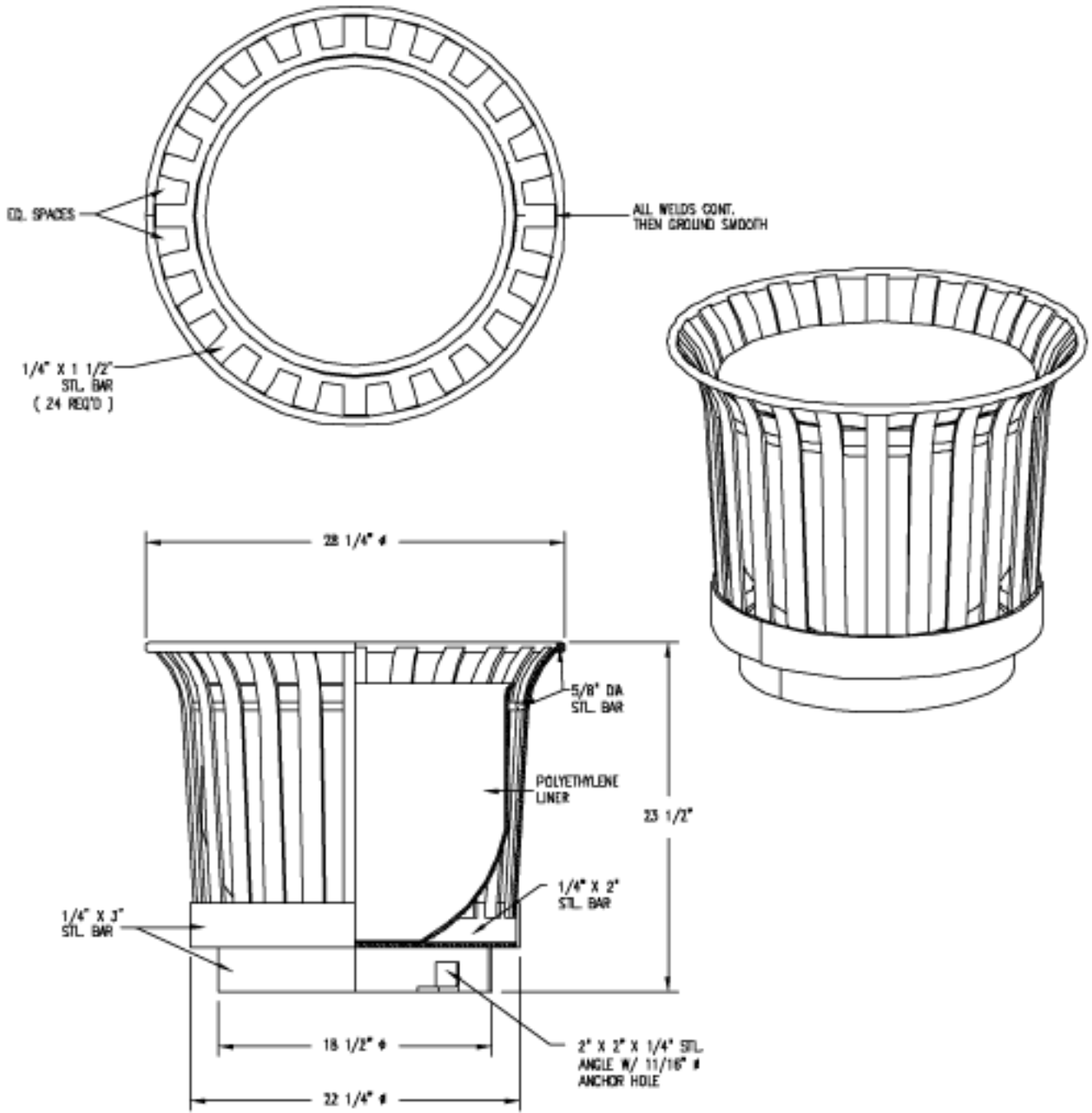

NOTES:

- 1.) ALL STL. MEMBERS COATED W/ ZINC RICH EPOXY THEN FINISHED W/ POLYESTER POWDER COATING.
- 2.) 1/2" X 3 3/4" PLTD. EXPANSION ANCHOR BOLTS PROVIDED.
- 3.) ALL WELDS CONTINUOUS THEN GROUNDED SMOOTH.

0
7
0
5
5
7

DuMor, inc.
P.O. Box 142 Mifflintown, PA 17059-0142

SCALE : NONE
DATE DRAWN : 9/10/99
DRAWN BY : HD
DATE REV. : 12/10/02
REV. BY : AMH

TITLE : PLANTER

REV. C
DRAWING NUMBER 114-00

SHEET 1 OF 2

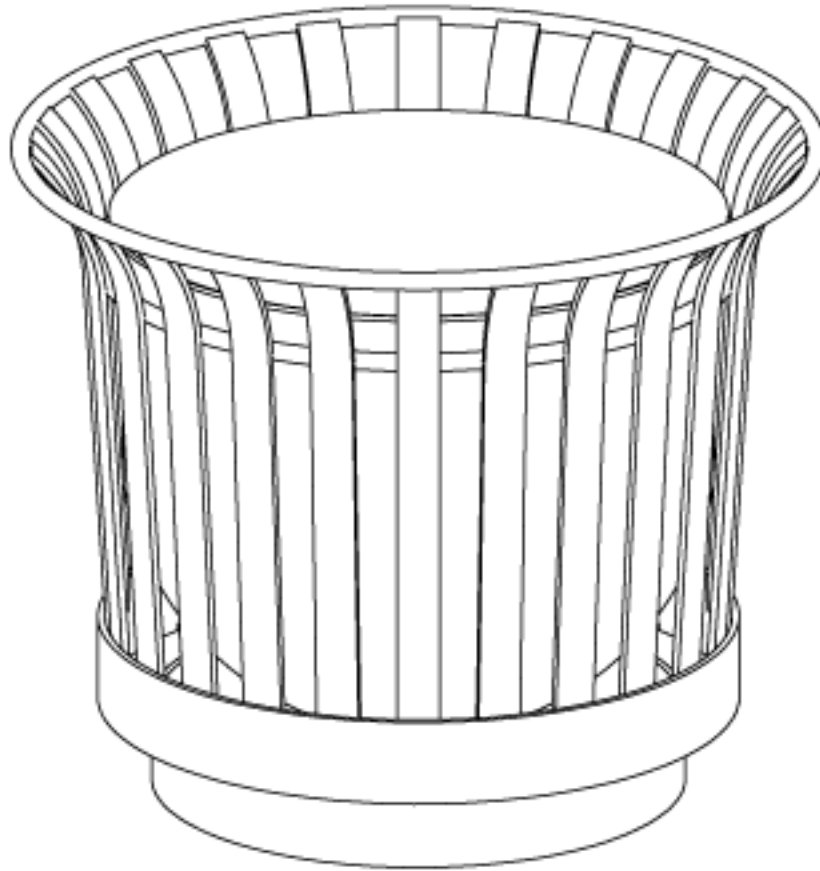

NOTE:

- 1.) SHIPPED FULLY ASSEMBLED.
- 2.) MOUNT AND ANCHOR AS SPECIFIED.

0
7
0
5
5
7



DuMor, inc.
P.O. Box 142 Mifflintown, PA 17059-0142

SCALE : NONE
 DATE DRAWN : 9/10/99
 DRAWN BY : HD
 DATE REV. : 12/10/02
 REV. BY : AMH

TITLE : PLANTER ASSEMBLY		DRAWING NUMBER 114-00	SHEET 2 OF 2
REV. C			

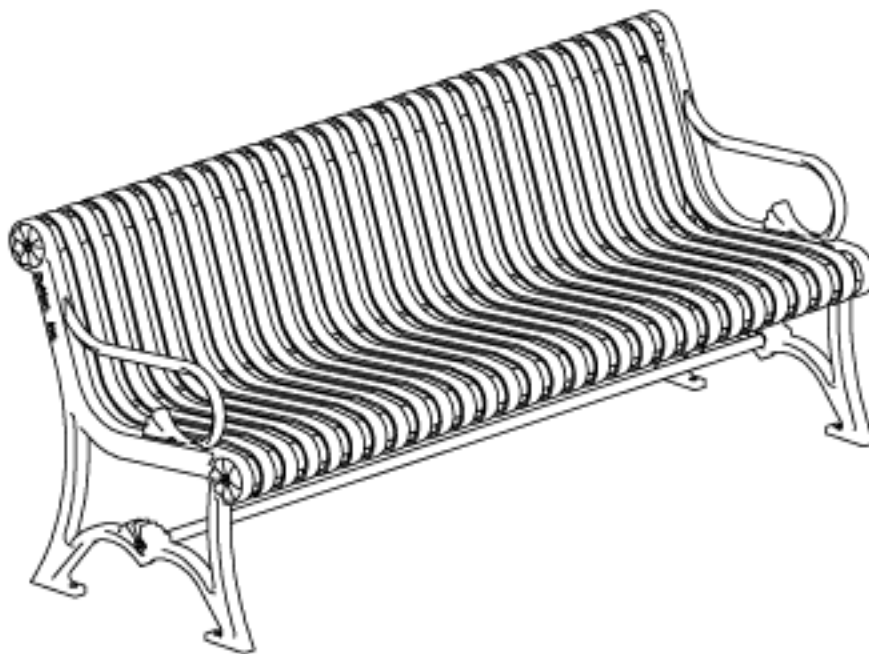
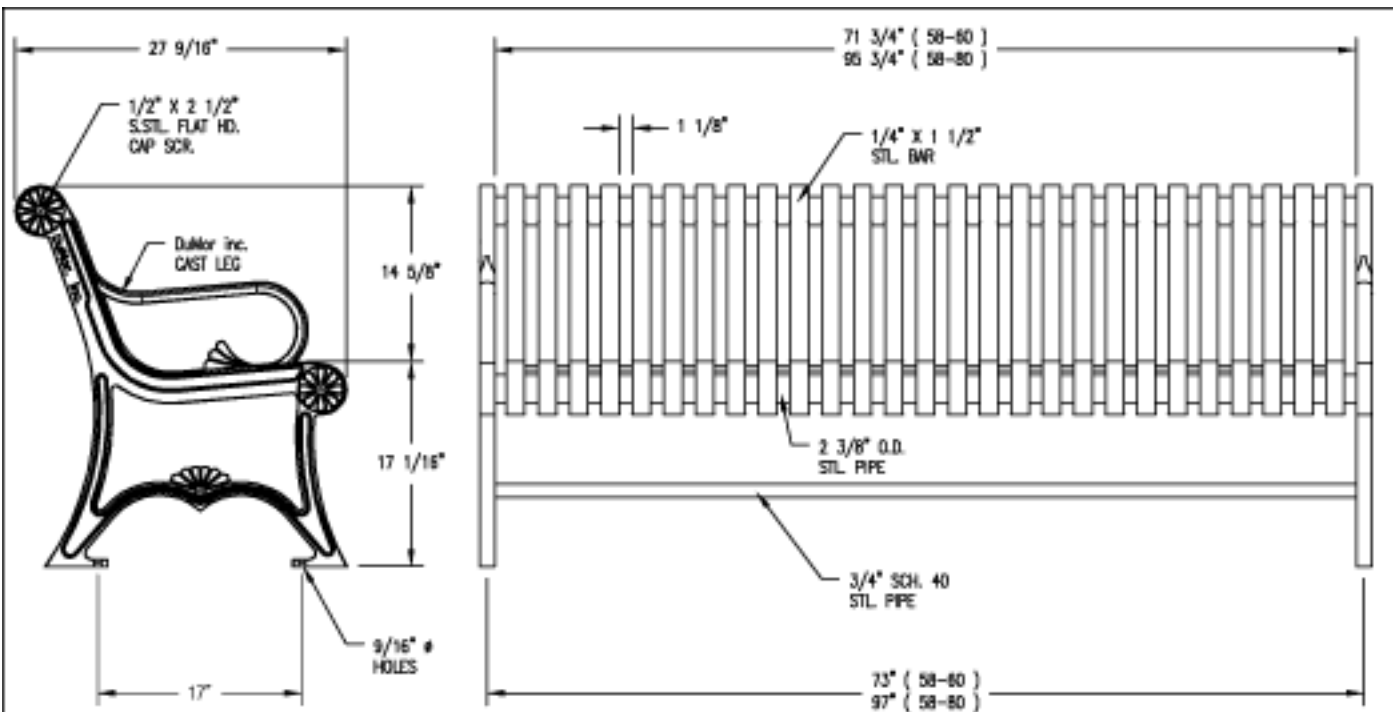

NOTES

- 1.) ALL STL. MEMBERS COATED W/ ZINC RICH EPOXY THEN FINISHED W/ POLYESTER POWDER COATING.
- 2.) $\frac{1}{2}'' \times 3 \frac{3}{4}''$ PLTD. EXPANSION ANCHOR BOLTS PROVIDED.
- 3.) CUSTOM LETTERING AVAILABLE FOR RECESSED SIDE PANELS (TOTAL OF 37 SPACES)

CUSTOM LETTERING (37 SPACES)

LENGTH OPTIONS

- 6' BENCH
- 8' BENCH

0
7
0
5
5
7

DuMor, inc.
P.O. Box 142 Mifflintown, PA 17059-0142

SCALE : NONE
DATE DRAWN : 3/22/94
DRAWN BY : AH
DATE REV. : 11/21/99
REV. BY : JSB

TITLE :
REV. D

BENCH

DRAWING NUMBER

58 SERIES

SHEET 1 OF 2

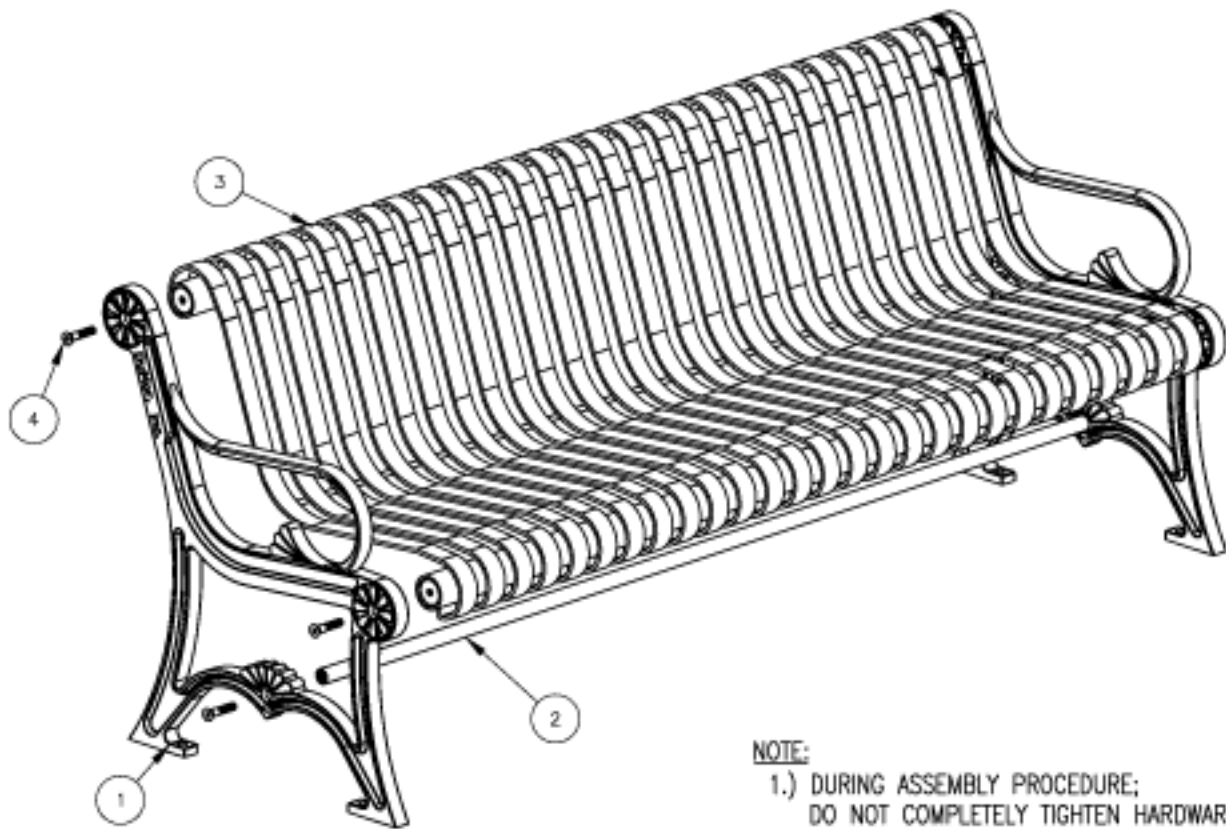

NOTE:

- 1.) DURING ASSEMBLY PROCEDURE;
DO NOT COMPLETELY TIGHTEN HARDWARE.
- 2.) THE ACTUAL PARTS WILL NOT BE NUMBERED;
NUMBERS ONLY APPLY TO DRAWING.

STEP 1:

USE 2 - PCS. CAST IRON BENCH SUPPORT (1)
 1 - PC. 6' ALL STL. SEAT ASSEMBLY (3)
 4 - PC. 1/2" X 2 1/2" FLT. SKT. HD. CAP SCR. (4)
 ATTACH CAST IRON BENCH SUPPORT (1) TO 6' ALL STL.
 SEAT ASSEMBLY (3) USING HARDWARE (4).
 TIGHTEN TO SNUG FIT.

STEP 2:

USE 1 - PC. 71 3/4" PIPE BRACE (2)
 2 - PCS. 1/2" X 2 1/2" FLT. SKT. HD. CAP SCR. (4)
 ATTACH 71 3/4" PIPE BRACE (2) TO STEP 1 ASSEMBLY
 USING HARDWARE (4). TIGHTEN TO SNUG FIT.

STEP 3:

UPON COMPLETION OF BENCH ASSEMBLY SQUARE ALL
 COMPONENTS THEN TIGHTEN ALL HARDWARE.

STEP 4:

MOUNT AND ANCHOR AS SPECIFIED.

070557

ITEM	QTY	PART NO	DESCRIPTION
1	2	0-57-00-02	CAST IRON BENCH SUPPORT
2	1	0-57-60-04	71 3/4" PIPE BRACE
3	1	0-58-60-01	6' ALL STL SEAT ASSEMBLY
4	6	1-12-065	1/2" X 2 1/2" FLT SKT HD CAP SCR



DuMor, inc.
 P.O. Box 142 Mifflintown, PA 17059-0142

SCALE : NONE
 DATE DRAWN : 3/22/94
 DRAWN BY : AH
 DATE REV. : 11/21/99
 REV. BY : JSB

TITLE : BENCH ASSEMBLY

REV. D	DRAWING NUMBER 58 SERIES	SHEET 2 OF 2
--------	--------------------------	--------------



SEAT ASSEMBLY ON WORK
ALLOWING ACCESS TO ENDS.



STEP #2

PLACE RATCHET STRAP AROUND SEAT
ASSEMBLY AS SHOWN ABOVE.



STEP #3

TIGHTEN STRAP UNTIL SHIPPING BRACKET
BECOMES LOOSE. THEN REMOVE AND DISCARD
BOLTS & SHIPPING BRACKET.



STEP #4

ATTACH CAST SUPPORT TO SEAT ASSEMBLY
USING 1/2" x 2 1/2" FLAT SOCKET HEAD
CAP SCREWS. IF HOLES IN CASTING DO NOT
ALIGN WITH THE SEAT ASSEMBLY, ADJUST
BY USING THE RATCHET STRAP.



STEP #5

TIGHTEN HARDWARE THEN REMOVE
RATCHET STRAP AND REPEAT THIS PROCEDURE
ON THE OTHER END OF BENCH.

J. Mor, inc.
142 Millintown, PA 17069-0142

DATE 8/19/99

DRAWN BY HD

BENCH SEAT ASSEMBLY

REVISION A

58 SERIES

EX. BRADFORD FEAR
- BROKEN
- REMOVE

EX. BRADFORD FEAR
- BROKEN
- REMOVE

EX.
- RE

1800 BLOCK WEST UNIVERSITY AVE.

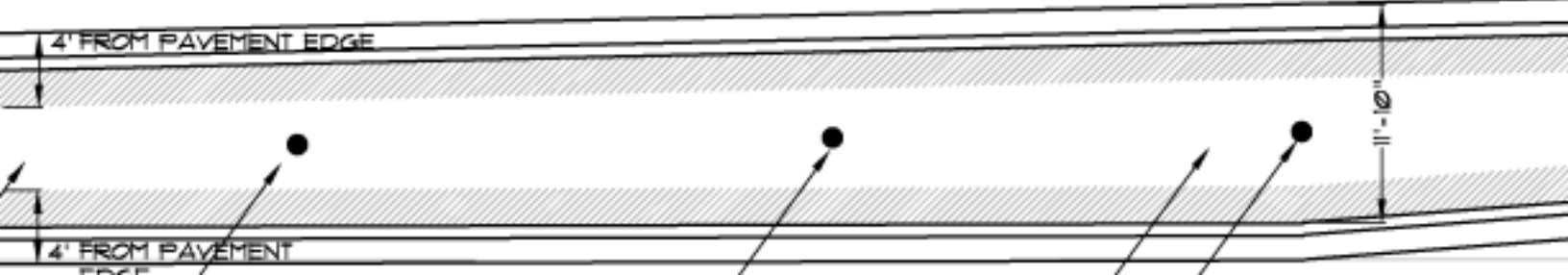
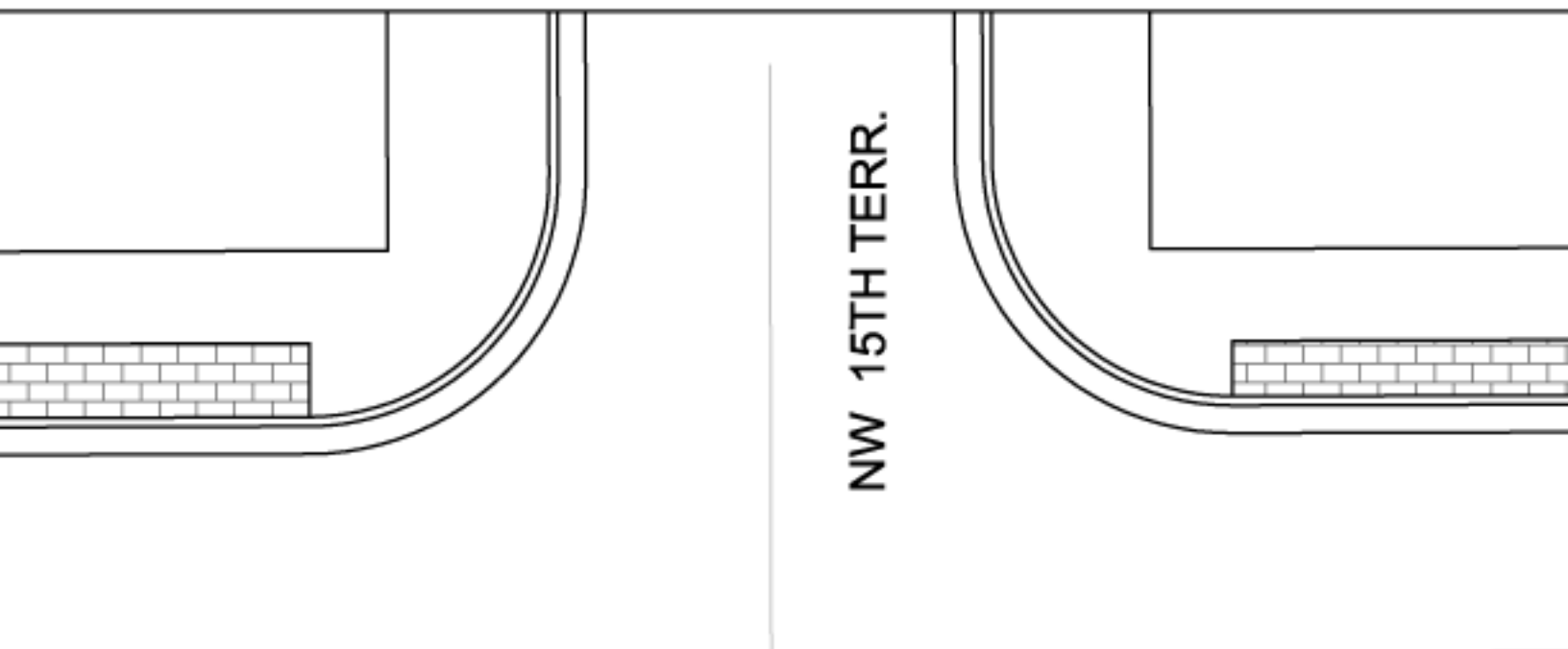

FROM
PAVEMENT
EDGE

REMOVE TREES AND ALL
EXISTING PLANT MATERIAL.

FDOT DE
SPEED
MEDIAN
CLEAR
INTERSE
CORRE
PLANTIN
FOLLOW
PLANTIN

1400 BLOCK WEST UNIVERSITY AVE.

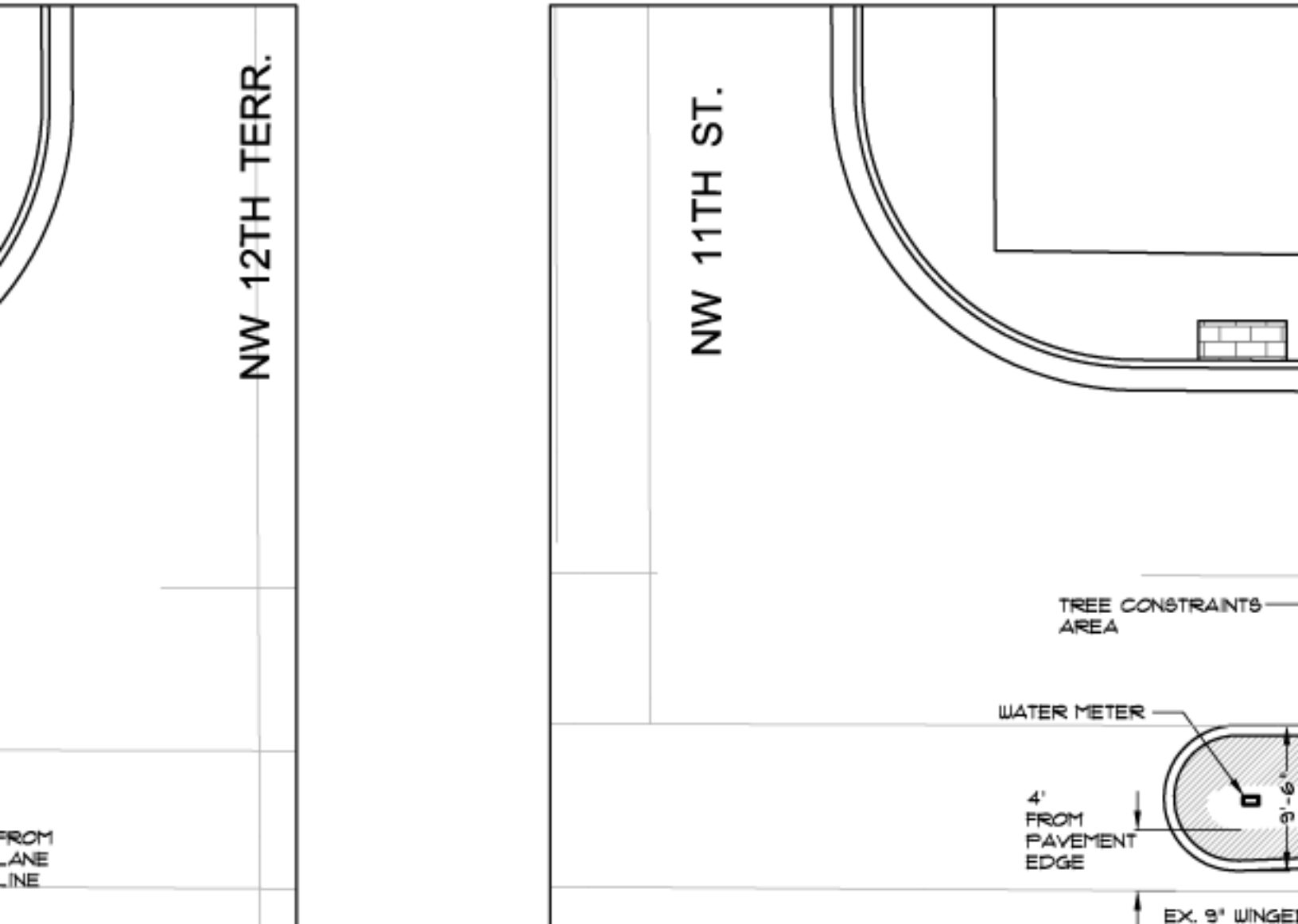

NW 12TH TERR.

NW 11TH ST.

TREE CONSTRAINTS
AREA

WATER METER

4'
FROM
PAVEMENT
EDGE

EX. 9' WINGE

FROM
LANE
LINE

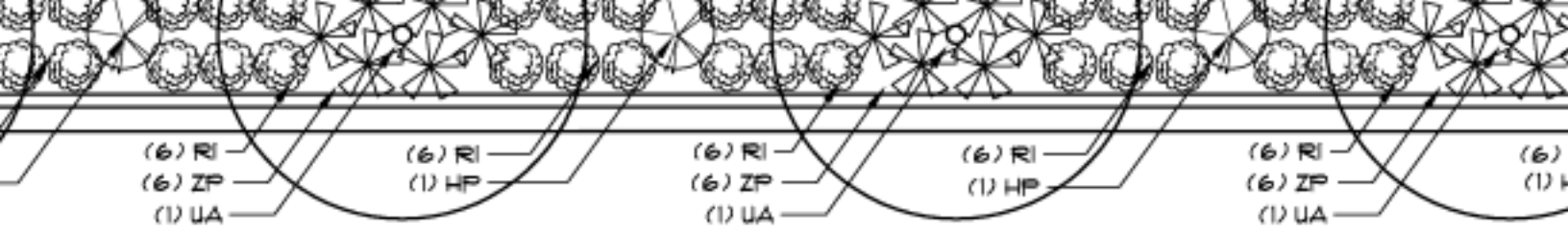

**1800 BLOCK
WEST UNIVERSITY AVE.**

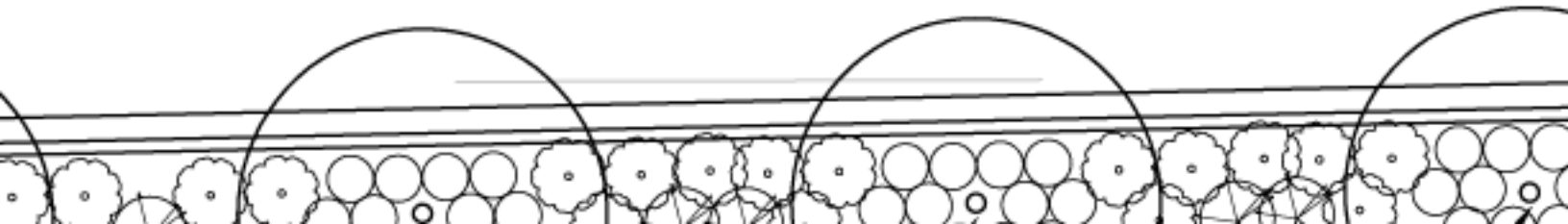
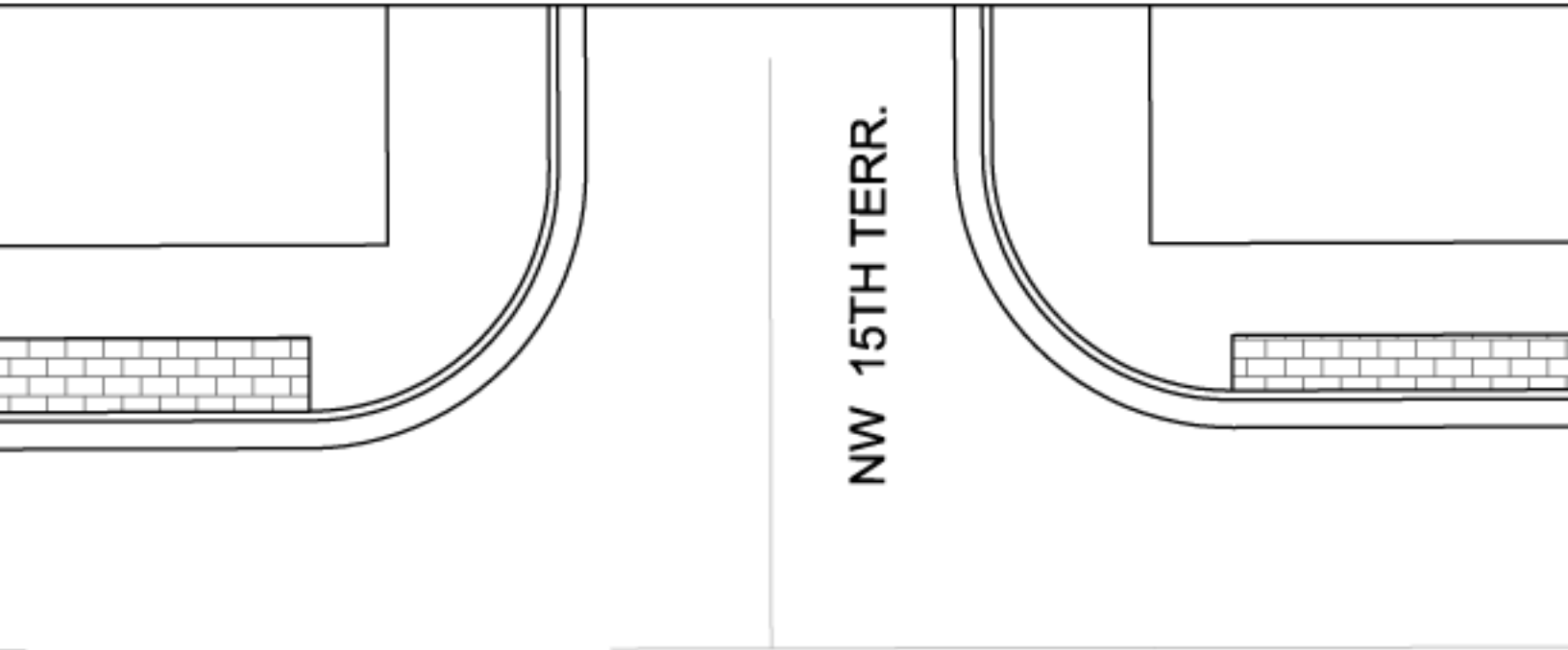

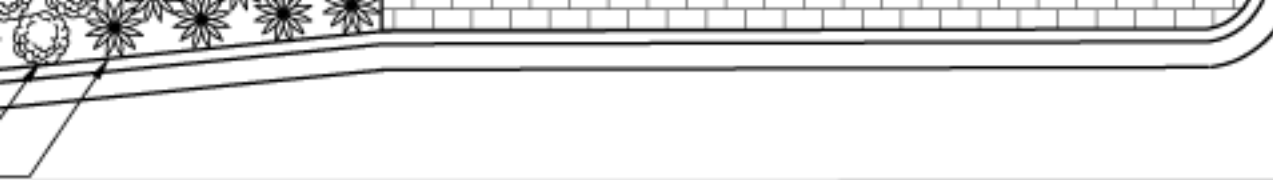

1400 BLOCK WEST UNIVERSITY AVE.

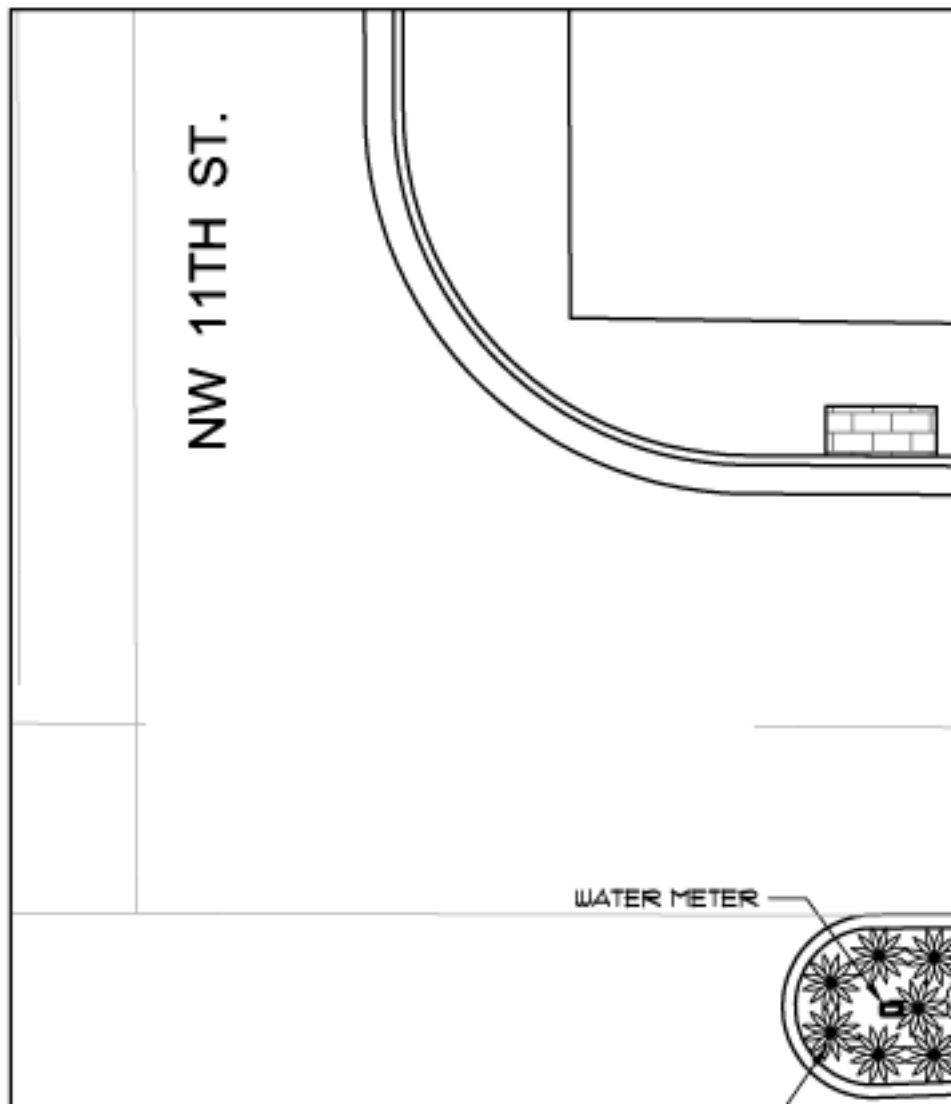
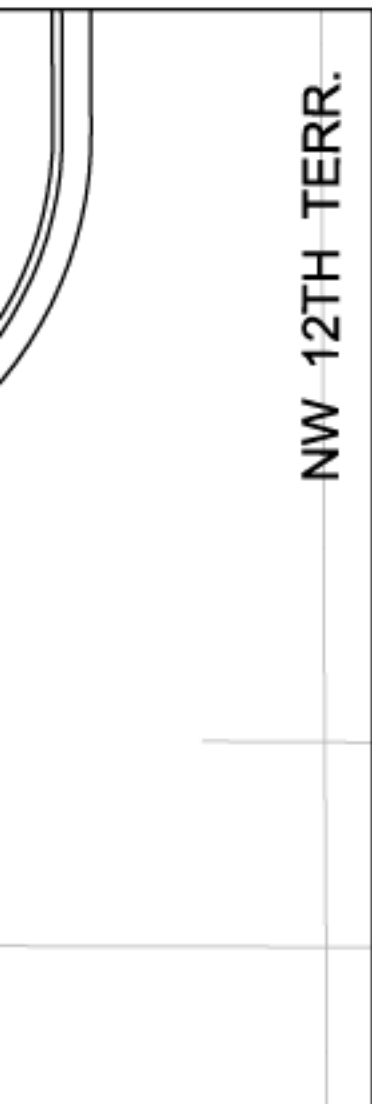

WATER METER



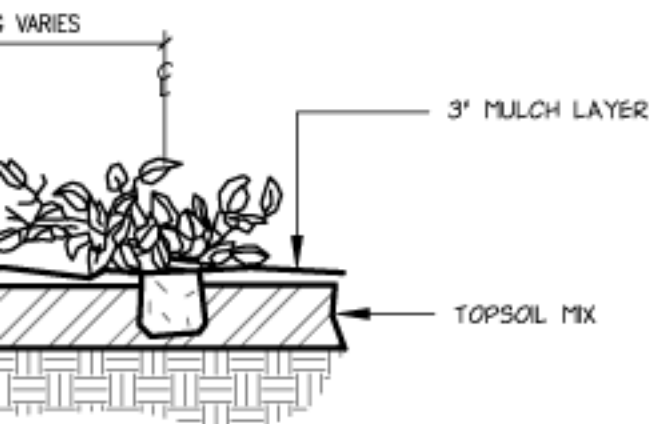

COVER PLANTING

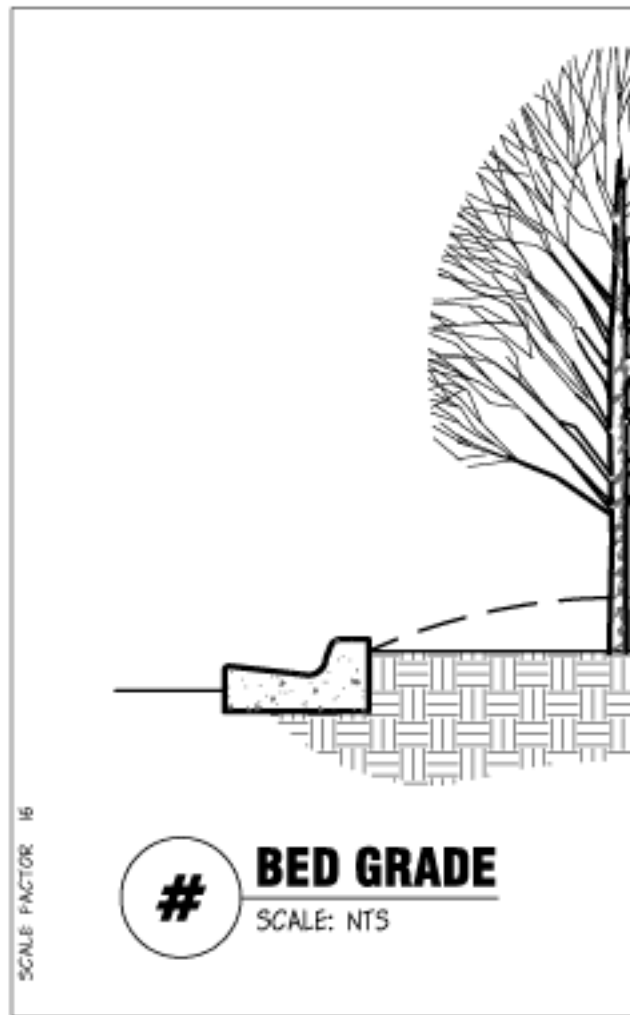

- BALL TO BEAR SAME RELATIONSHIP TO FINISH GRADE AS PREVIOUSLY HELD AT NURSERY.

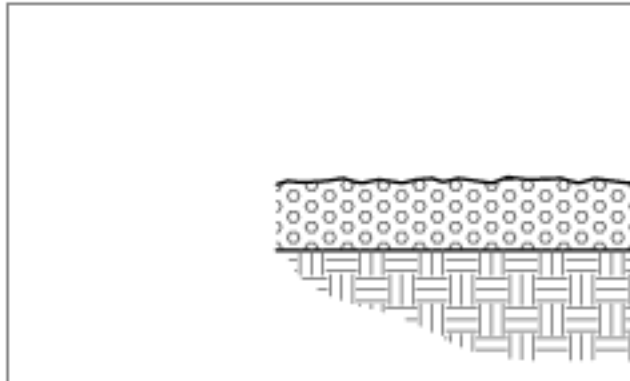

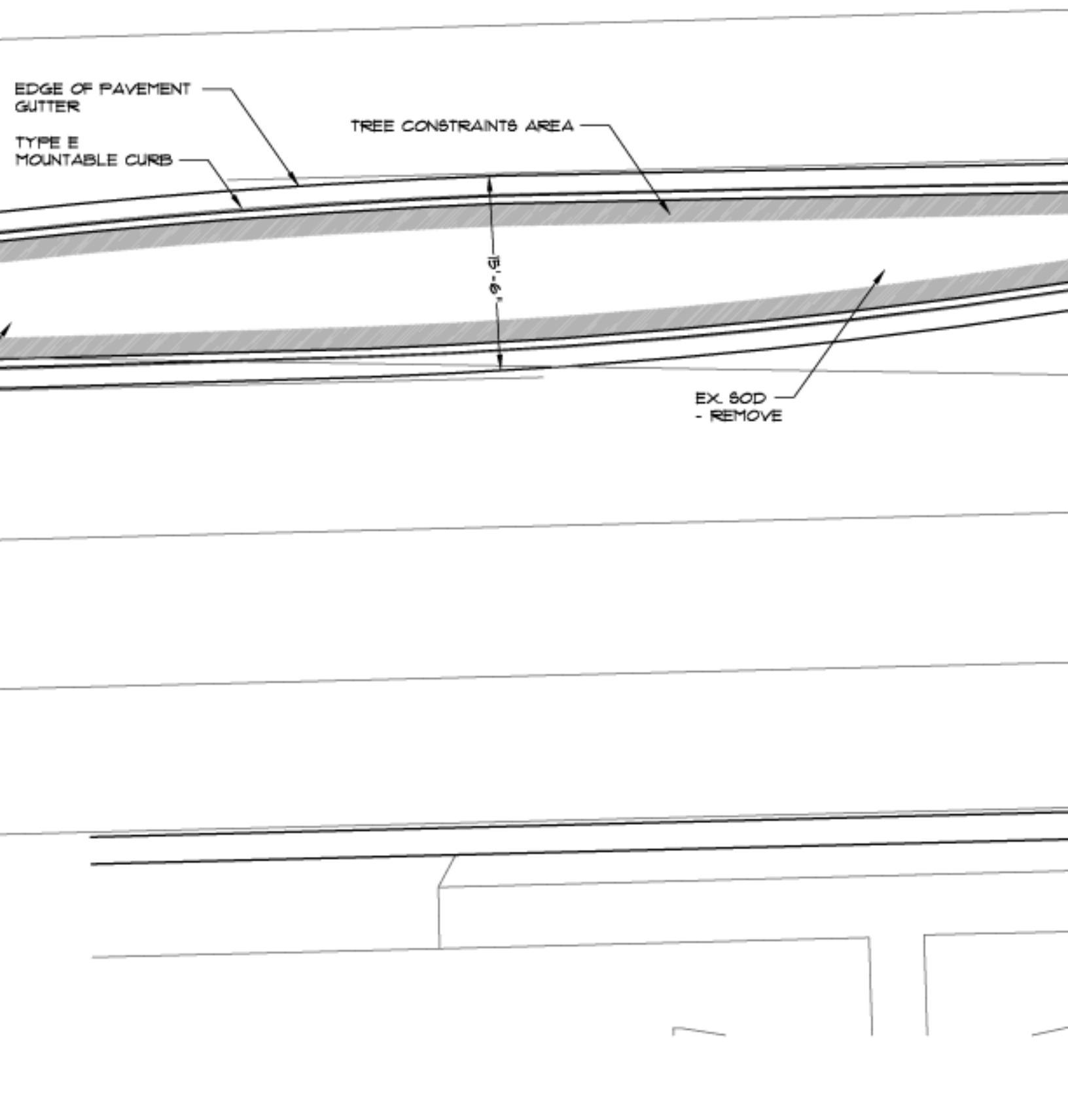

00 BLOCK
UNIVERSITY AVE.

FROM
PAVEMENT
EDGE

REMOVE TREES AND ALL
EXISTING PLANT MATERIAL.

FDOT DE
SPEED
MEDIAN
CLEAR
INTERSE
CORRE
PLANTIN
FOLLOW
PLANTIN

1400 BLOCK WEST UNIVERSITY AVE.

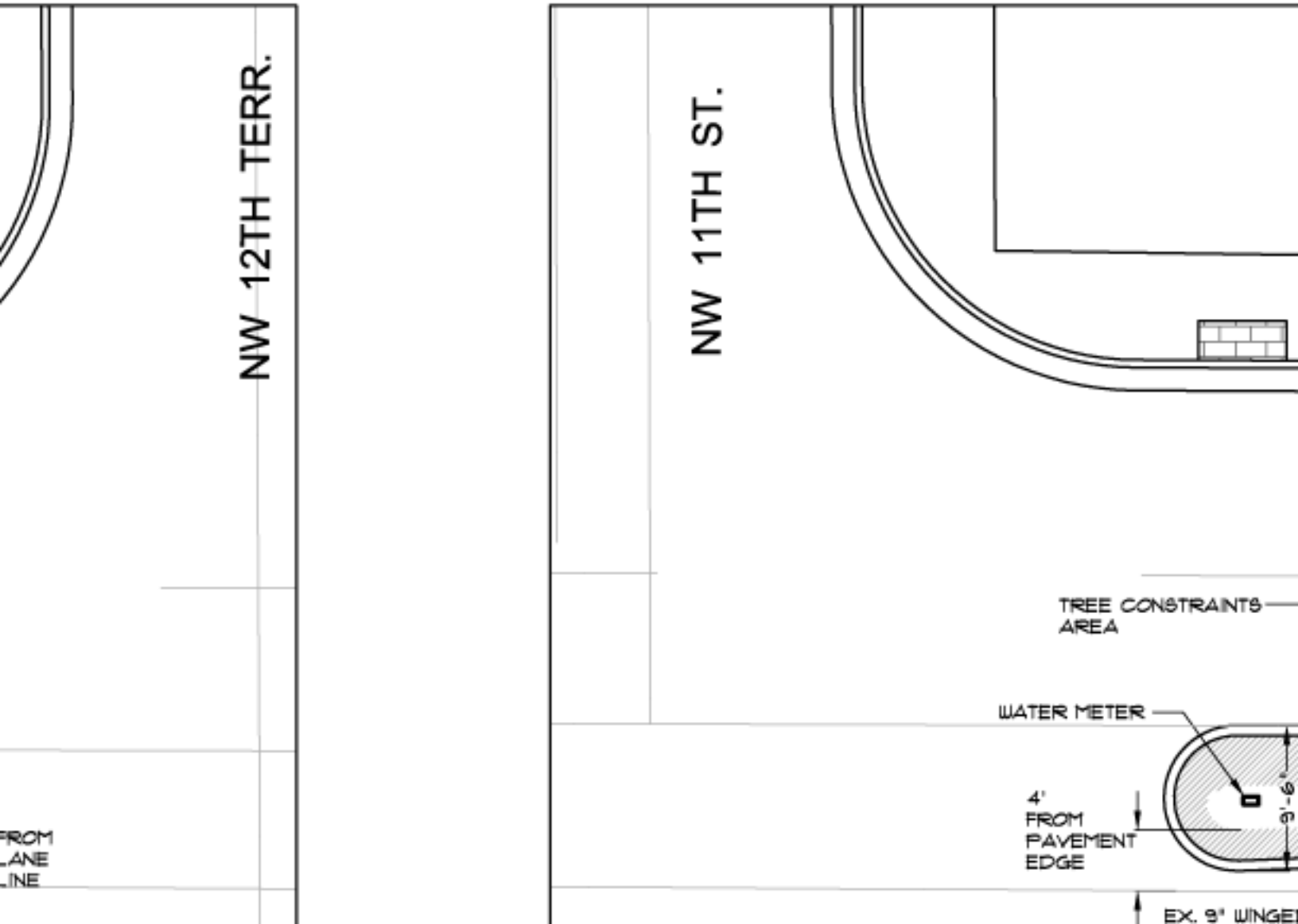

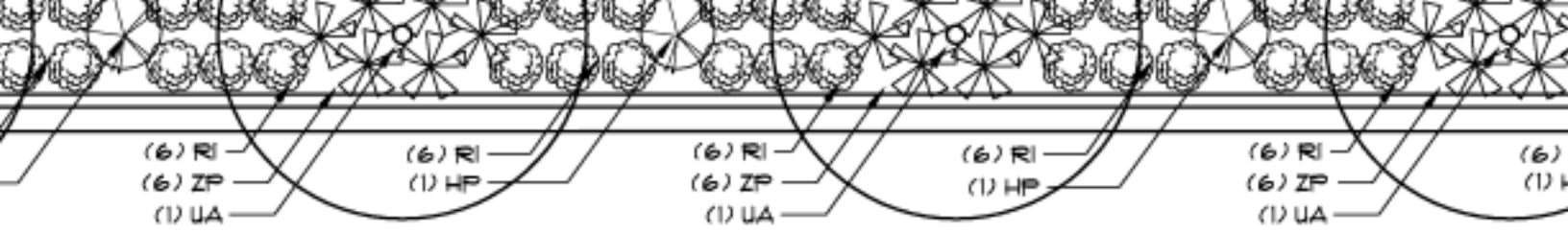

**1800 BLOCK
WEST UNIVERSITY AVE.**

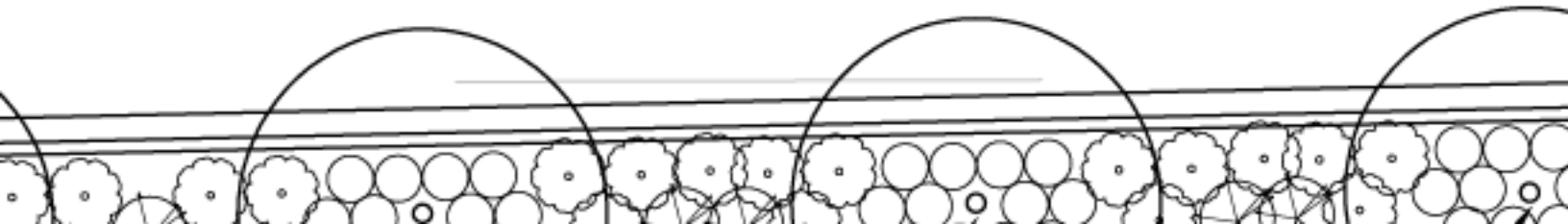
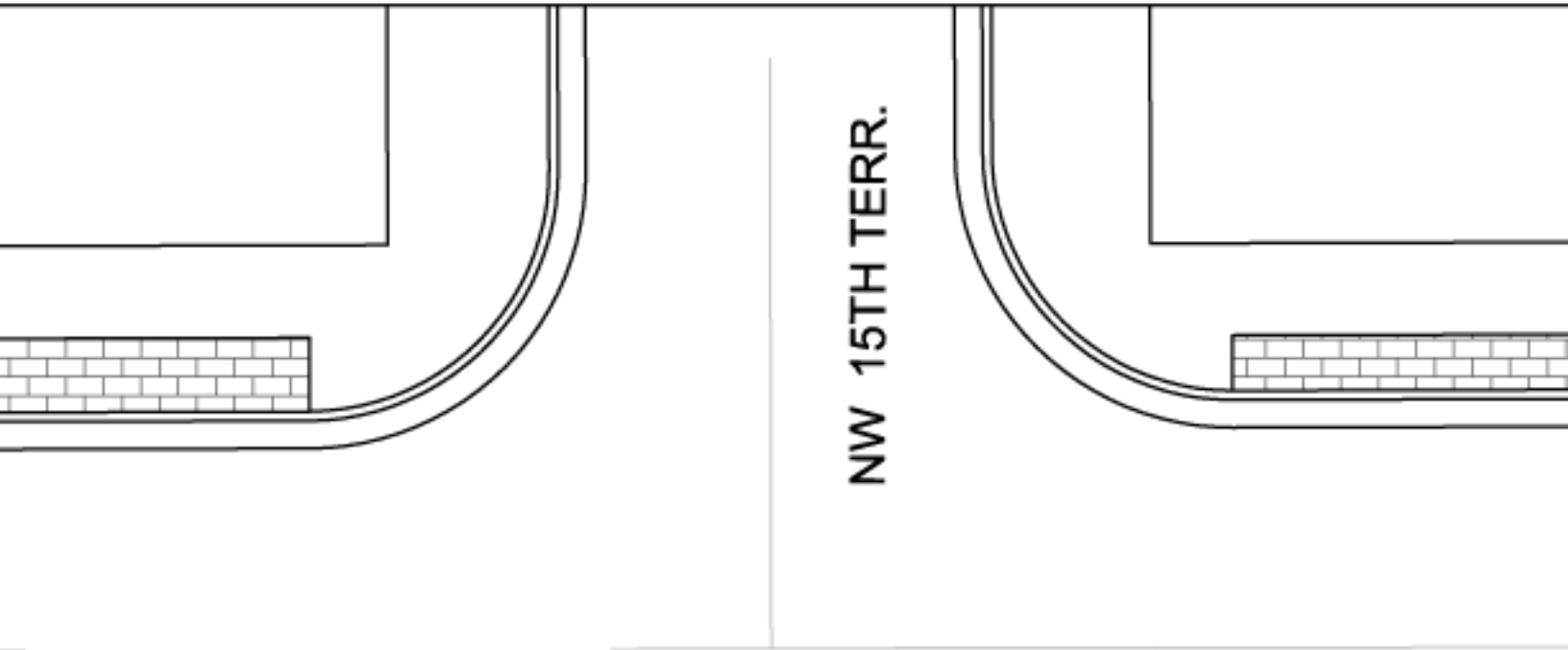

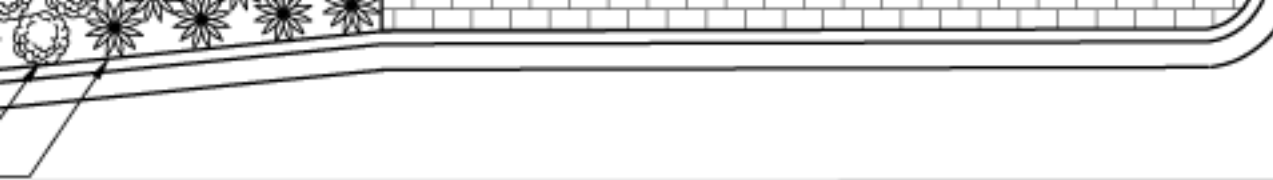

1400 BLOCK WEST UNIVERSITY AVE.

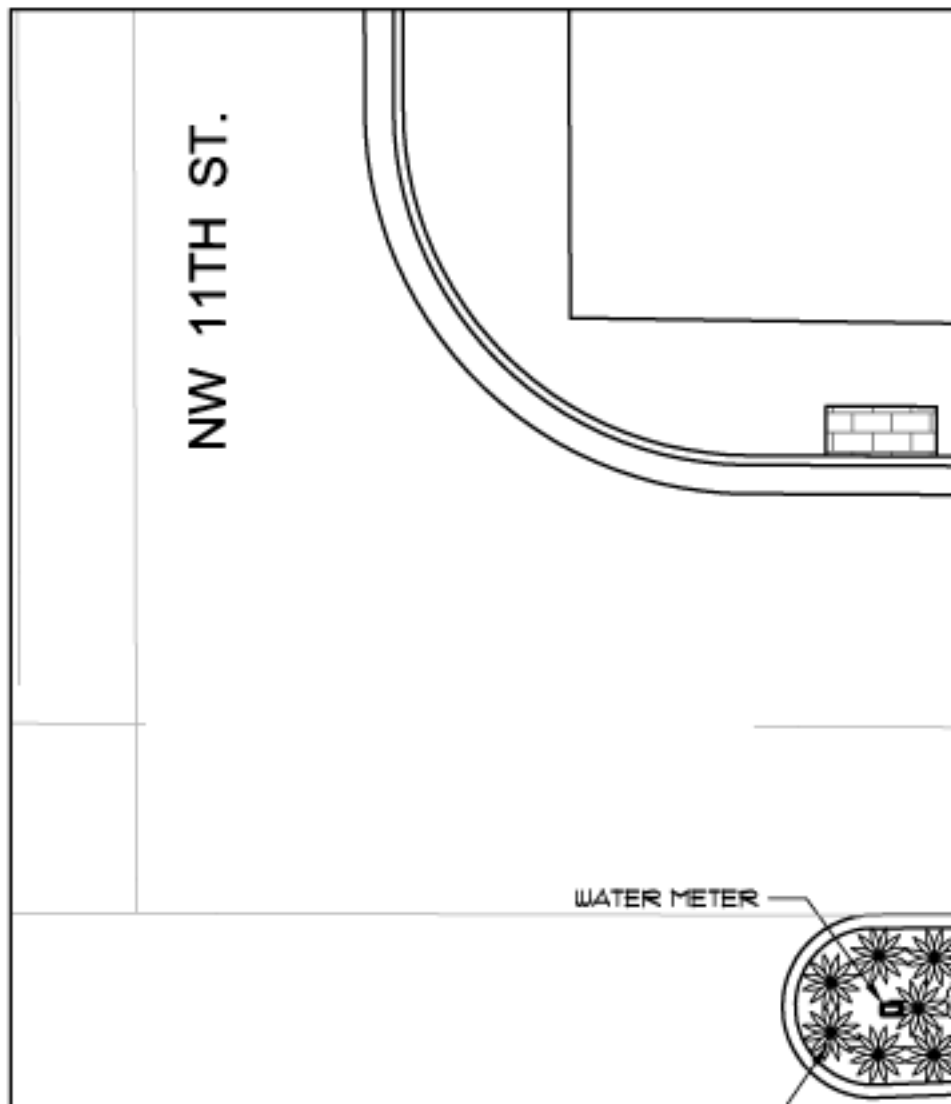
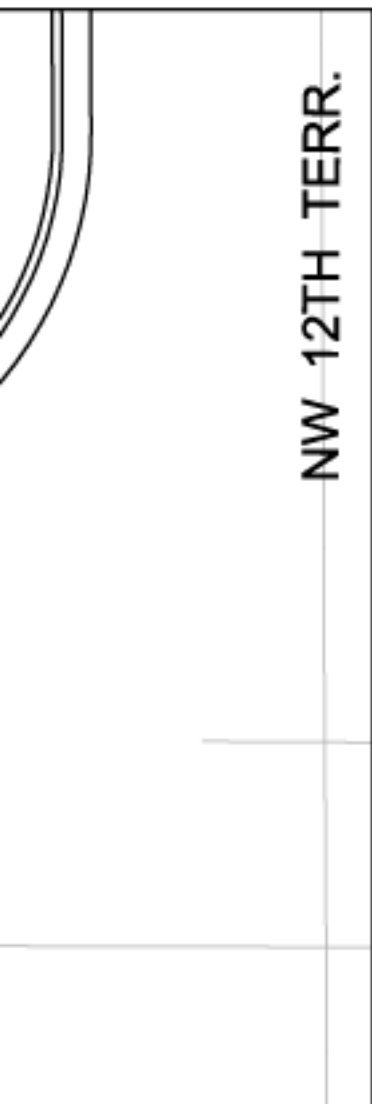

WATER METER



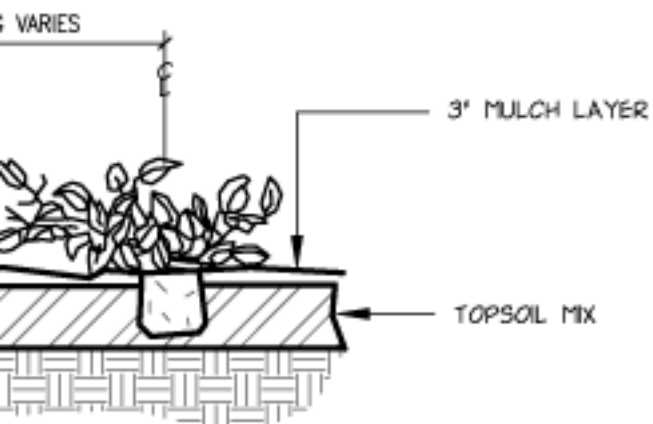

COVER PLANTING

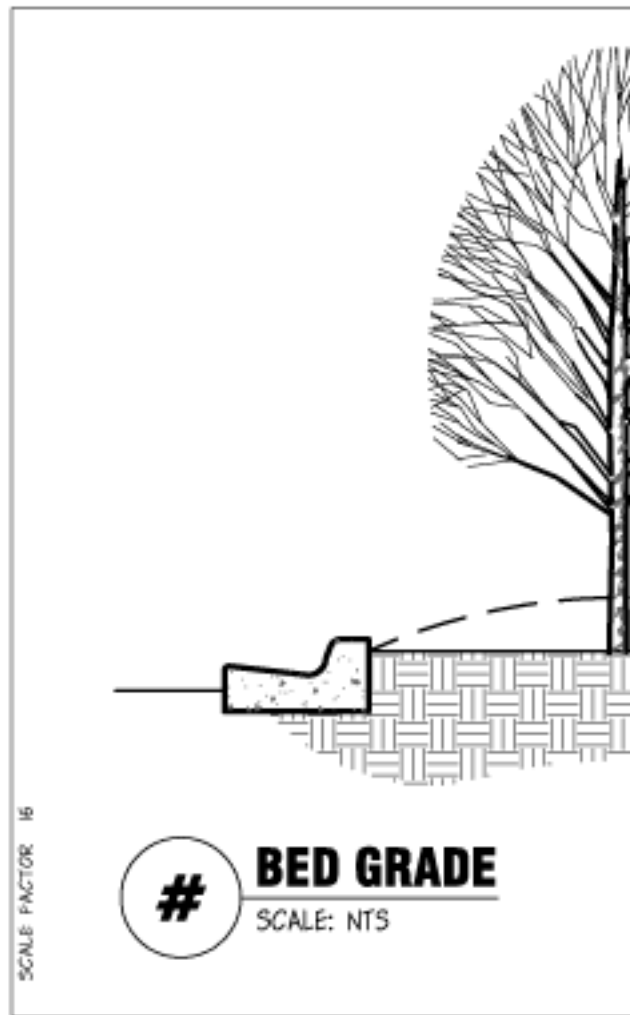

- BALL TO BEAR SAME RELATIONSHIP TO FINISH GRADE AS PREVIOUSLY HELD AT NURSERY.

