



Response Submittal,
GRU Solicitation No. 2015-024:
Request for Proposal (RFP)
for Transportation and Beneficial Reuse or
Disposal of Dewatered Biosolids

Watson C&D Contact Information:

Watson C&D, LLC
12890 NE SR 24
Archer, FL 32618
352-495-9449
Ryan McMeekin
ryan@watsoncll.com
Larry Watson
larry@watsonconstruct.com

6.1 Description of Proposed Process

a. Describe the proposed process for biosolids transportation and beneficial reuse or disposal.

Watson C&D intends to purchase a transport vehicle and three trailers for biosolids transportation. Biosolids will supplement Watson's existing composting operation, which have been ongoing for five years. In the case of surplus, land application for feed farmers would be a contingency plan, while an in-vessel composter was constructed to accommodate the biosolids overage.

b. Indicate whether the proposed process will receive Digested Class B Biosolids (as described in Section 2.1 of the INTRODUCTION) or Partially Digested Biosolids (as described in Section 2.2 of the INTRODUCTION), or if it has the ability to receive either one.

Watson C&D would prefer to receive Digested Class B Biosolids, but pending results of a pilot program with waste activated sludge, would be able to receive either one.

6.2 Company Background and Experience

Provide Respondent's general background including a summary of previous experience including the following:

a. Description of biosolids processing experience including a list of permitted facilities;

Watson C&D is currently undergoing a FDEP approved pilot study for Biosolids processing with our existing permitted compost operation in Levy County.

b. Number of years of experience in biosolids processing with similar types of biosolids; and

Watson C&D retains an in-house environmental engineer with over 40 years of experience with wastewater, wastewater treatment plants, and biosolids. Watson C&D does not currently have experience with biosolids, but has been composting other materials locally for five years.

c. Number of years Respondent's company has been in business

Watson C&D has been in business for 39 years, since 1976.

d. Describe the organizational structure of the Respondent, location of headquarters, number of facilities and offices, and number of employees.

Watson C&D began operations in the Construction & Demolition industry and moved into the recycling field to reduce our environmental impact. Watson began composting to further reduce the impact of yard waste and enhanced our composting product by adding commercial and intuitional waste and manure. Working with GRU Biosolids would further enhance the nutritional value of our compost to farmers and turf grass markets, reducing the need for



chemical nutrients, fertilizers, water consumption and further benefiting the environment.
Watson C&D currently operates 3 offices and 4 permitted facilities with 20 plus employees.

e. Provide in a separate envelope a copy of the most recent annual financial statement or report.

Mark the envelope with the Respondent's company name and the words "Financial Statement - Confidential".

See envelope provided labeled "Financial Statement-Confidential"

6.3 Permitting / Regulatory Compliance

a. Will the Respondent utilize an existing permitted facility(ies) with sufficient capacity and compliance history to handle GRU biosolids?

i. If not, explain how permitting would be obtained for the new facilities that will be utilized.

ii. Can the permits for the new facilities be obtained by December 1, 2015 to haul and receive GRU biosolids?

iii. If new facilities are unable to be permitted by December 1, 2015, provide a timeline of when permits will be obtained for the new facilities, and describe the interim plan and process and how the interim plan will be permitted.

Watson C&D will use an existing composting facility that is permitted for a pilot study by FDEP for biosolids application to compost. Watson C&D works with multiple farm facilities that could be permitted for land application as a contingency plan described in Section 6.1. At least one of these farms can be permitted by December 1, 2015.

b. Provide a history of compliance with applicable regulations for the Respondent's operation of facilities similar to the facilities that will be utilized for the proposed process.

Watson C&D has operated a C&D landfill locally for more than three decades with no violations or compliance issues with the Florida Department of Environmental Protection or the Alachua County Environmental Protection Department.

c. Can the Respondent receive GRU biosolids 4 to 5 days/week, 52 weeks/year during normal work week hours, Monday through Friday 7:00 am to 7:00 pm?

Watson C&D's hours of operation are Monday through Friday, 8:00 am to 5:00 pm, 52 weeks of the year, with exception for holidays. Plans can be made to accept biosolids on holidays as needed for this contract.

d. Can the Respondent manage GRU biosolids without constructing any processing facilities on

GRU property?

Watson C&D will not require any processing facilities on GRU property. All biosolids processing and composting efforts will take place at Watson's facilities.

6.4 Risk of Process Disruption

a. Does Respondent currently use the proposed process to receive and reuse or dispose of biosolids from other municipalities? If so please provide the following:

Watson C&D does not currently use the proposed process to receive biosolids from any other municipalities.

i. List of existing locations where the Respondent is utilizing this process and how long each location has been in operation; and

ii. List of current contracts with municipalities for which the Respondent is using this process.

b. If the Respondent does not have existing facilities that use this process, cite other facilities at which this process is being used successfully to receive and reuse or dispose of municipal biosolids.

Watson C&D uses an inoculate technology that has been used for similar applications in other areas including:

- **Disney World Reedy Creek Improvement District**
- **Compost USA Biosolids from Orange County and Pasco County**
- **Summit County, Colorado**
- **Denton, Texas**
- **A1 Organics in Colorado**

c. Explain potential impacts of regulatory changes on the viability of the proposed process.

Watson C&D has experienced a history of positive regulatory support for composting from the Florida Department of Environmental Protection. Our process is a key component to the City, County, and State efforts to achieve 75% waste reduction by 2020 (Florida Statute 403.7032).

d. In the event Respondent is unable to process biosolids for a period of time due to mechanical failure, process upset, weather, or other events, what are the contingency plans to ensure that the Respondent continues to receive GRU biosolids?

Biosolids will supplement Watson's existing composting operation, which have been ongoing for five years. In the case of surplus, land application for feed farmers would be a contingency plan, while an in-vessel composter was constructed to accommodate the biosolids overage.

6.5 Operation Flexibility

a. Can your process accommodate variations in GRU operations and needs with varying hauling volumes, time and days for management and preparations for holidays, WRF maintenance activities, storm events, and other events that may require adjustments in the schedules for the transportation and acceptance of biosolids?

Watson C&D has the flexibility to meet the needs of GRU on volume, hauling days, and hours regardless of the maintenance schedule, storms or other events that may interrupt the routine operation. We are a proud partner of the Florida Gators and Ben Hill Griffin Stadium's Zero Waste effort and have experience working with variable schedules and vegetative waste flows for our composting operation based on football games in the fall.

b. Does your process have the ability to receive either dewatered partially digested biosolids or waste activated sludge biosolids, OR does it require digested Class B biosolids (as described in Section 2.0 of the INTRODUCTION)?

Watson C&D is presently initiating a pilot study for waste activated sludge biosolids as mentioned in Section 6.3. It is our belief that we will have the ability to receive Class B digested, partially digested, and waste activated sludge biosolids pending the final results of the pilot study.

6.6 Enhanced Environmental Benefits

a. Describe how this process is environmentally beneficial or responsible.

The composting process is extremely beneficial to the environment. Compost products reduce waste, reduce water usage and reduce the need for chemical fertilizers. It is a natural process that does not require additional energy input to occur and provides a valuable finished product for farms and landscapes.

b. Are nutrients recycled and how?

Nutrients are recycled through the composting process and repurposed when compost is applied to landscapes and turf grass, reducing the need for artificial fertilizers and water consumption.

c. Does the process require minimal energy and/or is there energy recovery?

Watson's composting process is through static windrows, requiring very few energy inputs to produce the final compost product.

d. Are there any other environmental benefits?

Composting with biosolids would enhance the nutritional value of the finished compost from our process, further reducing the need for chemical fertilizers upon application, which



ultimately reduces chemical runoff and contamination of water bodies and the aquifer. Please see additional details on the CD provided about the environmental benefits of compost.

6.7 Local Preference

The Local Preference Ordinance applies to Solicitations for goods or services estimated to exceed \$50,000.

In solicitation of, or letting contracts for procurement of, supplies, materials, equipment and services, as described in the purchasing policies, the City Commission, or other purchasing authority, may give a preference to local businesses in making such purchase or awarding such contract in an amount not to exceed five percent of the local business' total price, and in any event the cost differential should not exceed \$25,000.

A "local business" means the Respondent has a valid business tax receipt, issued by the City of Gainesville at least six months prior to Response due date, to do business in said locality that authorizes the business to provide the goods, services, or construction services to be purchased, and a physical business address located within the limits of said locality, in an area zoned for the conduct of such business, from which the business operates or performs business on a day-to-day basis. Post office boxes are not verifiable and cannot be used for the purpose of establishing said physical address. In order to be eligible for local preference, the Respondent must provide a copy of the business tax receipt. The ordinance can be found at www.cityofgainesville.org. A Local Preference Decision Tree is attached.

A copy of City of Gainesville Recovered Materials Collector Renewal Application and Commercial Construction and Demolition Debris Collection Service Annual Franchise Fees is attached.

6.8 Local Economic Benefits

Does the Respondent proposed process create jobs within Alachua County or provide income or other economic benefits to the City or businesses within Alachua County.

Watson C&D has a history of creating local jobs and contributing to the Gainesville and Alachua County economy. Our existing compost operation is a very successful public-private partnership, helping the city reduce waste. This venture would create employment opportunities and service/maintenance opportunities for the related equipment.

6.9 Price and Contract Duration

a. Indicate the ability of the Respondent to provide the proposed service to GRU for contract durations of 5 years, 10 years, and 20 years.

See attached bid proposal form

b. For each of the above contract durations that the Respondent can provide, indicate the price in dollars (\$) per wet ton that the Respondent will charge GRU for that duration. If the price will escalate over the contract period, indicate the basis and/or amount the price will escalate.

See attached bid proposal form

6.10 Provide the Respondent's Certification Form located in the FORMS Section.

Please see attached Respondent Certification Form.

6.11 Provide Drug-Free Work Place Certification Form located in the FORMS Section.

Please see attached Drug-Free Work Place Certification Form.

6.12 Living Wage Ordinance

Please see attached Living Wage Decision Tree. Watson C&D employs less than 50 people, so the Living Wage Ordinance does not apply.



SOLICITATION No. 2015-024

FOR TRANSPORTATION AND BENEFICIAL REUSE OR DISPOSAL OF DEWATERED BIOSOLIDS

RESPONDENT'S CERTIFICATION

NAME OF CORPORATION, PARTNERSHIP, OR INDIVIDUAL: Watson C&D, LLC
 PHYSICAL ADDRESS: 12890 NE SR 24 Archer, FL 32618
 FEDERAL IDENTIFICATION #: 59-3080398 STATE OF INCORPORATION: FL (Seal)

I have carefully reviewed this Solicitation including the scope, submission requirements, general information, and the evaluation and award process.

I acknowledge receipt and incorporation of the following addenda, and the cost, if any, of such revisions has been included in the pricing provided.

Addenda 1 through 1 acknowledged (if applicable).

I further acknowledge that: Response is in full compliance with the specifications; or Response is in full compliance with the specifications **except** as specifically stated and explained in detail on sheets attached hereto and labeled "Clarifications and Exceptions".

I hereby propose to provide the goods/services requested in this Solicitation. I agree to hold pricing for at least **60** calendar days from the Solicitation due date. I agree that GRU's terms and conditions herein take precedence over any conflicting terms and conditions submitted for GRU's consideration, and agree to abide by all conditions of this Solicitation.

I certify that all information contained in this Response is truthful to the best of my knowledge and belief. I further certify that I am duly authorized to execute and submit this Response on behalf of the organization as its agent and that the organization is ready, willing and able to perform if awarded.

I further certify that this Response is made without prior understanding, agreement, connection, discussion, or collusion with any other person, company or corporation submitting an offer for the same product or service; no officer, employee or agent of GRU owns or will benefit more than 5% from award of this Solicitation; and the undersigned executed this Respondent's Certification with full knowledge and understanding of the matters therein contained.

Larry Watson 2-5-13
 AUTHORIZED SIGNATURE DATE
Larry Watson President
 PRINT NAME TITLE
352-495-9948
 TELEPHONE NUMBER
Watson@watsonconstruct.com
 E-MAIL ADDRESS
watsonc11.com
 WEBSITE

RESPONDENT'S CONTACT
 (for additional information)
Ryan McMeekir
 NAME
General Manager
 TITLE
352-258-9330
 PHONE
Ryan@watsonc11.com
 E-MAIL ADDRESS

If Respondent is not an individual, include authorization for the above individual to sign on behalf of the organization.

DRUG-FREE WORKPLACE CERTIFICATION FORM

Preference may be given to a business that certifies that it has implemented a drug-free workplace program. Pursuant to Section 287.087, Florida Statutes, whenever two or more competitive solicitations that are equal with respect to price, quality, and service are received by the State or by any political subdivision for the procurement of commodities or contractual services, a response received from a business that certifies that it has implemented a drug-free workplace program shall be given preference in the award process. Established procedures for processing tie Proposals will be followed if none of the tied providers has a drug free workplace program. In order to have a drug-free workplace program, a business shall:

1. Publish a statement notifying employees that the unlawful manufacture, distribution, dispensing, possession, or use of a controlled substance is prohibited in the workplace and specifying the actions that will be taken against employees for violations of such prohibition.
2. Inform employees about the dangers of drug abuse in the workplace, the business's policy of maintaining a drug-free workplace, any available drug counseling, rehabilitation, and employee assistance programs, and the penalties that may be imposed upon employees for drug abuse violations.
3. Give each employee engaged in providing the commodities or contractual services that are under proposal a copy of the statement specified in Subsection (1).
4. In the statement specified in Subsection (1), notify the employees that, as a condition of working on the commodities or contractual services that are under proposal, the employee will abide by the terms of the statement and will notify the employer of any conviction of, or plea of guilty or nolo contendere to, any violation of Chapter 893, Florida Statutes, or of any controlled substance law of the United States or any state, for a violation occurring in the workplace no later than five (5) days after such conviction.
5. Impose a sanction on any employee who is so convicted or require the satisfactory participation in a drug abuse assistance or rehabilitation program as such is available in the employee's community.
6. Make a good faith effort to continue to maintain a drug-free workplace through implementation of applicable laws, rules and regulations.

As the person authorized to sign the statement, I certify that this firm complies fully with the above requirements.

Watson C&D LLC
CORPORATION, PARTNERSHIP, OR INDIVIDUAL

7.15.15
DATE

[Signature]
AUTHORIZED SIGNATURE

LIVING WAGE ORDINANCE DECISION TREE

Solicitation Number: **2015-024**

Project Name: **TRANSPORTATION AND BENEFICIAL REUSE OR DISPOSAL OF DEWATERED BIOSOLIDS**

Contractor Name: Watson C&D, LLC

While not all encompassing, the following is provided as a guideline for contractors in determining whether the City of Gainesville Living Wage Ordinance (LWO) applies to their firm in the performance of specified service contracts for covered services* with GRU. Contractor is advised to review the entire text of the LWO at www.cityofgainesville.org.

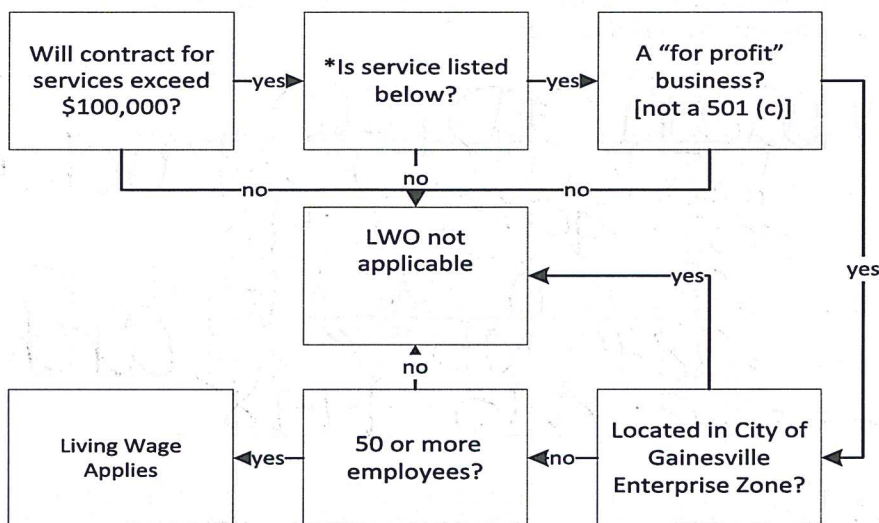

***Covered Services:** food preparation and/or distribution; custodial/cleaning; refuse removal; maintenance and repair; recycling; parking services; painting/refinishing; printing and reproduction services; landscaping/grounds maintenance; agricultural/forestry services; and construction services

(Use the flow chart and information above to help complete the remainder of the form below)

N/A Living Wage Ordinance does not apply
 Reason for Exemption:
 Service will not exceed \$100,000
 Not a covered service
 Company is not for profit
 Company is located in Enterprise Zone
 Company employs less than 50 persons
 Living Wage Ordinance applies

If the Living Wage Ordinance applies, indicate additional costs included in the Response price \$ N/A.

NOTE: If Contractor has stated Living Wage Ordinance does not apply and it is later determined that Living Wage Ordinance does apply, Contractor will be required to comply with the provision of the City of Gainesville's living wage requirements, as applicable, without any adjustment to the Response price.

**CITY OF GAINESVILLE
GAINESVILLE REGIONAL UTILITIES
CERTIFICATION OF COMPLIANCE WITH LIVING WAGE**

The undersigned hereby agrees to comply with the terms of the Living Wage Ordinance and to pay all covered employees, as defined by City of Gainesville Ordinance 020663 as amended at 030168 (Living Wage Ordinance), during the time they are directly involved in providing covered services under the contract with the City of Gainesville for TRANSPORTATION AND BENEFICIAL REUSE OR DISPOSAL OF DEWATERED BIOSOLIDS a living wage of \$11.4663 per hour to covered employees who receive Health Benefits from the undersigned employer and \$12.72 per hour to covered employees not offered health care benefits by the undersigned employer.

Responder Name:	Watson C&D, LLC	
Physical Address:	12890 NE SR 24 Archer, FL	32618
Phone Number:	352-495-9948	
Name of Local Contact Person:	Ryan McMeekin	
Physical Address:	12890 NE SR 24 Archer, FL	32618
Phone Number:	352-495-9948	
\$	N/A	
(Amount of Contract)		(Buyer)

Signature: 

Date: 2/5/2015

Printed Name: Larry Watson

Title: President

SUBCONTRACTOR INFORMATION FORM

List any subcontractors that will be used for the Work along with the goods or services to be provided. If the subcontractor is a small or minority-owned business, check the boxes that apply. The selected prime Contractor will be asked to provide the actual subcontractor spend amount at a later date.

Small Business Enterprise (SBE): An independently owned and operated business concern that employs 200 or fewer permanent full-time employees, and that, with its affiliates, has a net worth of not more than \$5,000,000.

Minority Business Enterprise (MBE): A business that is at least 51% owned by a minority person. A minority is defined as a lawful permanent resident of Florida who is (a) African-American, (b) Asian-American, (c) Hispanic-American, (d) Native-American, or (e) American women.

Subcontractor Name	Goods or Service to be provided	Business Type	
		SBE	MBE
None			

**LOCAL PREFERENCE POLICY ORDINANCE
DECISION TREE**

While not all encompassing, the following is provided as a guideline for determining whether the City of Gainesville Local Preference Policy Ordinance (LPPO) applies to solicitation Proposals submitted to the City. LPPO applies only to new solicitations. Respondents are advised to review the entire text of the Local Preference Policy Ordinance. Contractor is advised to review the entire text of the LPPO at www.cityofgainesville.org.

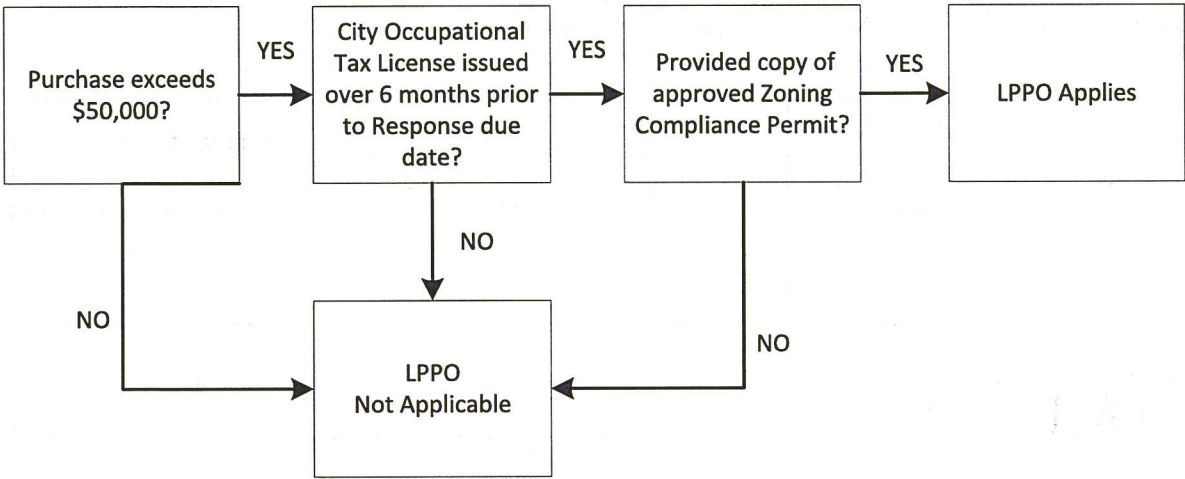

N/A

NON SUBMITTAL FORM

TO: Gainesville Regional Utilities Purchasing Department
301 S.E. 4th Avenue, Gainesville, Florida 32601

Fax: (352) 334-2989

Email: purchasing@gru.com

SOLICITATION NO.: 2015-024 FOR TRANSPORTATION AND BENEFICIAL REUSE OR DISPOSAL
OF DEWATERED BIOSOLIDS

BUSINESS: N/A

ADDRESS: _____

CONTACT: _____

PHONE: _____

EMAIL: _____

DATE: _____

Business declines to respond to the referenced Solicitation for the following reason(s):

- Do not offer product or service or product specified.
- Schedule conflict or unavailability.
- Insufficient time to respond to the Solicitation.
- Unable to meet specifications.
- Unable to meet the insurance requirements.
- Unable to meet bond requirements.
- Not interested at this time.
- Other _____

Please consider business for future solicitations: yes ___ no ___

Please consider business on solicitations for these products/services:

Comments: _____



DEBARMENT/SUSPENSION/TERMINATION

Debarment/Suspension. The purchasing representative is authorized to suspend a vendor from consideration for award of contracts if there is probable cause to believe that the vendor has engaged in activity which might lead to debarment. The suspension shall be for a period not to exceed three months. After reasonable notice to the vendor involved and reasonable opportunity for that vendor to be heard, the purchasing representative, after consulting with the City Attorney, is authorized to debar a vendor for cause from consideration for award of contracts. The debarment shall be for a period of not more than three years. The causes for debarment include:

- (a) Conviction for commission of a criminal offense as an incident to obtaining or attempting to obtain a public or private contract or subcontract, or in the performance of such contract or subcontract, within five years of a proposed award;
- (b) Conviction under State or Federal statutes of embezzlement, theft, forgery, bribery, falsification or destruction of records, receiving stolen property, or any other offense indicating a lack of business integrity or business honesty which currently, seriously, and directly affects responsibility as a City contractor, within five years of a proposed award;
- (c) Conviction under state or federal antitrust statutes arising out of the submission of bids or proposals, within five years of a proposed award;
- (d) Violation of contract provisions, as set forth below, of a character which is regarded by the purchasing representative to be so serious as to justify debarment action, within five years of a proposed award:
 - (I) Deliberate failure without good cause to perform in accordance with the specifications or within the time limit provided in the contract; or
 - (II) A record of failure to perform or of unsatisfactory performance in accordance with the terms of one or more contracts; provided that failure to perform or unsatisfactory performance caused by acts beyond the control of the contractor shall not be considered to be a basis for debarment;
- (e) For any provision of, or offer, gift or agreement to provide, any gratuity, kickback or offer of employment to any current or former City employee in connection with any decision, approval, disapproval, recommendation, or preparation of any part of a program requirement or a purchase requisition, influencing the content of any specification or procurement standard, rendering of advice, investigation, auditing, or in any other advisory capacity in any proceeding or application, request for ruling, determination, claim or controversy or other particular matter, pertaining to any program requirement or a contract or subcontract, or to any solicitation or proposal, within three years of a proposed award;
- (f) For any payment, gratuity, kickback or offer of employment to be made by or on behalf of a subcontractor under a contract to the prime contractor or higher tier subcontractor or any person associated therewith, as an inducement for the award of a subcontract or order, within three years of a proposed award;
- (g) For retaining a person or soliciting or securing a GRU contract upon an agreement or understanding for a commission, percentage, brokerage, or contingent fee, except for retention of bona fide employees or bona fide established commercial selling agencies for the purpose of securing business, within three years of a proposed award;
- (h) During the period of a contract with GRU, employing, or offering employment to, any current City employee participating directly or indirectly in the procurement process, within three years of a proposed award;
- (i) Any other cause the purchasing representative determines to be so serious and compelling as to affect responsibility as a City contractor, including debarment by another governmental entity for any cause listed in this Section;
- (j) The foregoing is supplemental to any applicable provisions of F.S. 287.133, as amended. In the event of any conflict between this provision and the requirements of said statute, the statute shall prevail.

REJECTION OF BIDS/TERMINATION OF CONTRACT

Previously solicited and/or accepted bids may be rejected or acceptance revoked prior to beginning of performance upon discovery by GRU that the bidder or its affiliates have committed any act which would have been cause for debarment, or were on the convicted vendor list prepared under the provisions of F.S. 287.133, as amended, at or prior to the acceptance of the bid.

If GRU discovers, after a contract is awarded and performance has begun, that the bidder or its affiliates have committed any act subsequent to or prior to award or acceptance which would have been cause for debarment had it been discovered prior to award or acceptance, GRU may consider such to be a material breach of the contract and such shall constitute cause for termination of the contract.

Revised 8/20/10

ATTACHMENT A

GRU Biosolids Generation Estimates

Biosolids Generation estimates are based on digestion level and will vary depending on the contractor/process selected. Actual material to be hauled is estimated to be between the no digestion * and full digestion ** quantities. Centrifuge dewatering efficiency may also vary the amount of material hauled daily. Annual Averages are shown as well as hauling estimates for typical 5-day week operations (Wet Tons/Day)

Year	No Digestion (DT/Yr)	Full Digestion (DT/Yr)	No Digestion (WT/Yr)	Full Digestion (WT/Yr)	No Digestion (WT/Day) ~20% TS Annual Ave	Full Digestion (WT/Day) ~20% TS Annual Ave	No Digestion (WT/Day) ~20% TS Hauling 5 day/Wk	Full Digestion (WT/Day) ~20% TS Hauling 5 day/Wk
2013	4656	3572	23282	17860	64	49	89	69
2014	4724	3344	23621	16722	65	46	91	64
2015	4791	3384	23957	16918	66	46	92	65
2016	4867	3423	24335	17114	67	47	93	66
2017	4942	3462	24711	17310	68	47	95	66
2018	5017	3501	25085	17505	69	48	96	67
2019	5091	3540	25456	17701	70	48	98	68
2020	5165	3579	25826	17897	71	49	99	69
2021	5238	3619	26190	18093	72	50	100	69
2022	5310	3658	26552	18289	73	50	102	70
2023	5382	3697	26912	18485	74	51	103	71
2024	5454	3736	27272	18681	75	51	105	72
2025	5526	3775	27629	18876	76	52	106	72
2026	5595	3814	27975	19072	77	52	107	73
2027	5664	3854	28320	19268	78	53	109	74
2028	5733	3893	28663	19464	79	53	110	75
2029	5801	3932	29007	19660	79	54	111	75
2030	5870	3971	29349	19856	80	54	113	76
2031	5938	4010	29691	20052	81	55	114	77

* No Digestion Biosolids Estimates performed by CH2MHILL, based on historical flow data & WAS production
 ** Full Digestion Biosolids Estimates based on linear regression analysis from GRU Biosolids Summary Reports 1994 to 2031
 KWRWF $y = 46.466X + 1555.1$ $R^2 = 0.6849$
 MSWRF $y = -7.2946X + 1240.8$ $R^2 = 0.1294$
 Total System $y = 39.171X + 2796$ $R^2 = 0.4481$

Watson C&D Proposal based on Attachment A: GRU Biosolids Generation Estimate

\$34.50/WT

Annual Rate: \$705,076.50 based on estimated annual quantity

5 Year Contract: \$3,525,382.50

10 Year Contract: \$7,050,765,00

20 Year Contract: \$14,101,530.00



Larry Watson

City of Gainesville
Public Works Department
Recovered Materials Collector Renewal Application

Applicant Information:

Name WATSON GAD LLC
Address 12890 NE SR 24
City/State/Zip Code GAINESVILLE ARLINGTON FL 32618
Phone Number 352-495-9449

Service Type Requested:

- Renewal of application to provide for the collection and disposal of recovered materials.

To the applicant: A certificate of registration shall be valid for one year and shall be renewed annually up to two times upon completion of application requirements as set forth by Florida statute. Please provide the required information as an attachment to the registration renewal application requirement checklist.

Registrant Renewal Application Requirements
And Requirement Checklist

1. Payment of renewal fee specified in Appendix A (Fee Schedule, Attachment A);
2. Two copies of notarized statement disclosing names of owners, general and limited partners, or corporate or registered name under which registrant will conduct business as authorized by City ordinance;
3. Registrant shall provide proof of insurance and maintain types and amounts of insurance from companies authorized to do business in the State of Florida to include:
- City of Gainesville shall be named as an additional insured on the general liability insurance if registrant uses city facilities;
 - General liability insurance in amount of \$500,000 per occurrence if the registrant utilizes City facilities;
 - Business automobile insurance as required by Florida statute;
 - Workers compensation as required by Florida statute.;
4. Registrant shall provide proof that the registrant is still providing service to customers;
5. Registrant shall state whether it is a processor of materials, transporter, or both.

City of Gainesville
Public Works Department
Recovered Materials Collector Renewal Application

Applicant agrees to comply with all provisions of the City of Gainesville, Florida Code of Ordinances Article III, Division 3 of Chapter 27 consisting of Sections 27-85 through 27-88.

WATSON CAD LLC
Applicant name (Print or Type)

[Handwritten Signature]
Applicant signature

10/15/14
Application submission date

Application received by date

Application fee received by check number check date

Approved City Manager/designee signature date

City of Gainesville
Public Works Department
Recovered Materials Collector Renewal Application

Affidavit

The below named person, as applicant or legal representative for applicant, does hereby certify that all required information has been attached to this application and become a part thereof.

Applicant or applicant's legal representative agrees that applicant will comply with all provisions of the City of Gainesville Code of Ordinances, the laws, rules, ordinances and regulations of Alachua County, the State of Florida and of the United States.

WATSON C&D LLC
Applicant name

Ryan McMeekin
Name of applicant's legal representative

GENERAL MANAGER
Title of applicant's legal representative

[Signature]
Signature of applicant

[Signature]
Signature of applicant's legal representative

Witnesses:

Witness signature

Witness signature

STATE OF FLORIDA
COUNTY OF ALACHUA

The foregoing instrument was acknowledged before me this 20th day of October, in the year 2014, by Ryan McMeekin, ~~President and Secretary,~~ respectively, of Watson C&D LLC, a Florida corporation, on behalf of the corporation.

They/he/she are/is personally known to me or has produced _____ as identification.

Print Name: Turi Stevens
My Commission Expires: 8/1/2017

[Signature]
Notary Public, State of Florida



Attachment A
Application Fee Schedule

Non-refundable Commercial Services Franchise and Recovered Materials Collector Registration application fees as specified in Appendix A of the Gainesville Code of Ordinances related to fees, rates and charges are as follow:

I. Commercial Services Franchise Application (Ref. 27-80):

The non-refundable franchise application fee, payable with franchise application, shall be valid for the terms of the franchise.

	<u>Application Fee</u>
1. Container provision <u>only</u>	\$105.00
2. Construction and demolition debris collection and disposal services	\$262.50
3. Solid waste collection and disposal services	\$262.50
4. Solid waste collection and disposal services, plus construction and demolition collection and disposal services	\$262.50

II. Recovered Materials Collector Registration Application and Renewal Application (Ref. 27-86):

The non-refundable registration application fee, payable with registration or renewal application, shall be valid for one year. If a registrant has been granted a commercial services franchise, no franchise application fee (I.) will be required until such time as the commercial franchise would have terminated (Ref. 27-79).

1. Registration application	\$52.50
2. **Registration yearly renewal application	\$52.50

****Note:** A certificate of registration shall be valid for one year, and shall be renewed annually up to two times upon completion of the renewal application to include:

1. Payment of renewal fee;
2. Disclosure of ownership;
3. Proof of insurance as of renewal time;
4. Proof of continued services to customers;
5. Requirements as prescribed by City ordinance and Florida statute.

**COMMERCIAL CONSTRUCTION AND DEMOLITION
DEBRIS COLLECTION SERVICE ANNUAL FRANCHISE FEES
CITY OF GAINESVILLE, FLORIDA**

REPORTING DATE: 10/15/14 SERVICE PERIOD: October 1, 2013 thru September 30, 2014

<p>Submit payment of ALL completed forms to: City of Gainesville Solid Waste Division, Sta. 10, Attn: Joni Rollen 405 NW 39 Ave Gainesville, FL 32609 Make check out to City of Gainesville</p>
--

1. NUMBER OF VEHICLES HAVING 10 OR MORE WHEELS: 3 X \$1,575.00 = \$ 4,725.00
(Multiply number of vehicles by \$1,575.00)
2. NUMBER OF VEHICLES HAVING 6 TO 9 WHEELS: _____ X \$1,050.00 = \$ _____
(Multiply Number of vehicles by \$1,050.00)
3. NUMBER OF VEHICLES HAVING 5 OR FEWER WHEELS: _____ X \$525.00 = \$ _____
(Multiply number of vehicles by \$525.00)
4. Application fee (\$262.50) and/or Recycling registration fee (\$52.50) = \$ 52.50
5. TOTAL FRANCHISE FEES DUE TO CITY OF GAINESVILLE: \$ 4,777.50 ✓
(Sum of dollar amounts from lines 1-4 above)

AFFIDAVIT

I CERTIFY THAT THIS REPORT IS FILED IN COMPLIANCE WITH THE CITY OF GAINESVILLE CODE OF ORDINANCES AND THIS IS A TRUE STATEMENT OF SOLID WASTE FRANCHISE FEES DUE THE CITY.

NAME Ryan McMEELIN SIGNATURE 
(Please type or print)

TITLE GENERAL MANAGER COMPANY WATSON CAD LLC

MAILING ADDRESS 12890 NE SR 241 Archer FL 32618
Street City State Zip

TELEPHONE NUMBER (352) 495-9449

PAYMENTS/REPORTS SHOULD BE FILED ON OR BEFORE THE 15TH OF OCTOBER EACH YEAR. A PENALTY OF 1.0% PER MONTH WILL BE ASSESSED ON DELINQUENT PAYMENTS.

CITY OF GAINESVILLE OFFICE USE ONLY

DATE POSTMARKED _____

OF DAYS LATE _____

PENALTY DUE @ 1.0% _____

DATED BILLED _____

Acct. # 420-800-8080-0404 - Franchise Payments

Acct. # 420-800-8080-0409 - Late Fees

Attachment B
Compensation Payments for Construction and Demolition
Debris Collection Service

Commercial franchisees providing construction and demolition debris collection service shall pay as compensation to the City of Gainesville an annual fee calculated as follow (Ref. 27-80):

- | | |
|---|------------|
| 1. For each vehicle having ten (10) or more wheels | \$1,575.00 |
| 2. For each vehicle having more than five (5) and less than ten (10) wheels | \$1,050.00 |
| 3. For each vehicle having four (4) or five (5) wheels | \$ 525.00 |

Compensation payments for construction and demolition debris collection service shall be due on the 15th day of October of each year, and will be accepted as timely if postmarked on or before October 15th, or the next succeeding workday if October 15th falls upon a Saturday or Sunday or state or federal holiday.

Payments not received by the due date shall be assessed interest at the rate of one percent per month compounded monthly from the due date.

Commercial franchisees providing construction and demolition debris collection service shall provide a list of type, number and complete description of all equipment to be used by applicant for providing safe and efficient services in order to be granted a franchise by the City of Gainesville (Ref. 27-82). (Vehicle List, Attachment C).

City of Gainesville
Public Works Department
Commercial Services Franchise Application

Applicant Information:

Name WATSON GAD LLC
Address 12690 NE SR 24
City/State/Zip Code ARCHER FL 32618
Phone Number 352-495-9449

Service Type Requested:

- To provide containers only;
- To provide construction and demolition debris collection and disposal services as defined by City ordinance;
- To provide commercial solid waste collection and disposal services as defined by City ordinance.

To the applicant: The following information is provided to assist you in preparing your application for a non-exclusive franchise to provide containers for commercial services and/or to provide commercial solid waste collection and disposal services and/or construction and demolition debris collection and disposal services to properties located in the City of Gainesville. Please provide the required information as an attachment to the franchise application requirement checklist.

Sec. 27-81(c) Each commercial franchisee providing commercial service shall file an annual report including a schedule of total gross revenues as defined in section 27-80(a). This annual report shall be examined by an independent certified public accountant to certify that the computation of gross revenue used to calculate franchise fees remitted is in accordance with the terms of the franchise.

Franchise Application Requirements
And Requirement Checklist

- 1. Name(s) and business address(es) of principal officers and stockholders and other persons having financial or controlling interest in any partnership or corporation;
- 2. Name(s) and business address(es) of local managing officers of any publicly owned corporation having more than 25 shareholders;
- 3. Criminal convictions, withheld adjudication and/or plea of nolo contendere for any felonies of any individual having controlling interest in applicant's firm, corporation, partnership, association or organization, and a statement of whether such applicant operates(ed) a solid waste collection business in this or any other state or territory under a franchise, permit or license, where, and whether such franchise, permit or license has ever been revoked or suspended, and the reasons therefor;
- 4. Proof that corporation is in good standing in the State, and if not a Florida corporation, proof that applicant is qualified to do business in the State of Florida;

City of Gainesville
Public Works Department
Commercial Services Franchise Application

- 5. If applicant is other than a corporation, and is operating under a fictitious name, applicant shall be required to submit information that such fictitious name is registered and held by applicant;
- 6. List of type, number and complete description of all equipment to be used by applicant for providing safe and efficient services (**Note: Construction and demolition debris collection and disposal services franchise applicants must also complete Vehicle List, Attachment C**);
- 7. Applicant shall maintain in full force and effect insurance as specified, and file with the City Manager a certificate of insurance for all policies written in applicant's name, to remain on file with the City for the franchise term to include:
 - comprehensive general liability policy;
 - policy in applicant's name covering operations in amount not less than \$200,000 per occurrence for bodily injury;
 - policy in applicant's name covering operations in amount not less than \$200,000 per occurrence for property damage;
 - policy in applicant's name covering operations in amount not less than \$100,000 per person;
 - policy in applicant's name for bodily injury in amount of \$200,000 per occurrence;
 - policy in applicant's name for property damage liability regarding automobile liability insurance in amount of \$50,000 per occurrence; and
 - workers compensation as required by Florida statute;
- 8. Applicant shall pay the City a nonrefundable application fee as specified in Appendix A (Application Fee Schedule, Attachment A).

Definitions:

1. **Applicant:** a person applying to the City of Gainesville for a franchise to provide commercial service or collect construction and demolition debris within the City for hire, remuneration or other consideration.
2. **Franchisee:** person or corporation to whom the City has issued a non exclusive franchise to provide containers for commercial services and/or to provide commercial solid waste collection and disposal services or construction and demolition debris collection and disposal services to properties in the City.
3. **Registrant:** shall be a person who has made application with the City to collect, transport, convey or process recovered materials in the city and has subsequently received a registration certificate from the City. (Note: a franchisee may be a registrant).

City of Gainesville
Public Works Department
Commercial Services Franchise Application

Applicant agrees to comply with all applicable provisions of the City of Gainesville, Florida Code of Ordinances Article III, Divisions 1 and 2 of Chapter 27 consisting of Sections 27-71 through 27-84 as may be amended.

WATSON CHD LLC
Applicant name (Print or Type)

[Signature]
Applicant signature

10-15-14
Application submission date

Application received by date

Application fee received by check number check date

Approved City Manager/designee signature date

**City of Gainesville
Public Works Department
Commercial Services Franchise Application**

Affidavit

The below named person, as applicant or legal representative for applicant, does hereby certify that all required information has been attached to this application and become a part thereof.

Applicant or applicant's legal representative agrees that applicant will comply with all provisions of the City of Gainesville Code of Ordinances, the laws, rules, ordinances and regulations of Alachua County, the State of Florida and of the United States.

WATSON CAD LLC
Applicant name

RUAN MCMEEKIN
Name of applicant's legal representative

GENERAL MANAGER
Title of applicant's legal representative

[Signature]
Signature of applicant

[Signature]
Signature of applicant's legal representative

Witnesses:

Witness signature

Witness signature

STATE OF FLORIDA
COUNTY OF ALACHUA

The foregoing instrument was acknowledged before me this 20th day of October in the year 2014, by Ruan McMeekin, President and Secretary, respectively, of WATSON CAD LLC, a Florida corporation, on behalf of the corporation.

They/he/she are/is personally known to me or has produced as identification.

Print Name: Teri Stevens
My Commission Expires: 8/1/2017

[Signature]
Notary Public, State of Florida

Page 4 of 4



Public Works Department
Solid Waste Division, MS10
405 NW 39 Ave
Gainesville, FL 32609
(352) 334-2330, (352) 393-7980 (FAX)
www.gainesvillerecycles.com

September 15, 2014

Watson C & D
Attn: Larry Watson
12890 NE SR 24
Archer, FL 32618

RE: ANNUAL C&D FRANCHISE FEE

Dear Mr. Watson:

The annual franchise fee payment for providing construction and demolition debris collection services for the period **October 1, 2014 through September 30, 2015** is due on or before October 15, 2014. Companies not submitting payment by November 15, 2014 will have their franchise license suspended.

Enclosed are the necessary forms you will need to complete in order to continue providing this service. All forms should be mailed to the Solid Waste Division, Attn: Joni Rollen (see form). Your check should be made out to the City of Gainesville. Please, remember to **include your current updated Certificate of Liability Insurance for our records.**

If you have any questions, please contact me at 352-393-7964.

Thank you for your cooperation.

Sincerely,

Joni Rollen
Recycling Program Assistant

Cc: Steve Joplin, Solid Waste Manager

Enclosures (6)

Attachment C
Construction and Demolition Debris Collection Service Vehicle List

List the type, number and description of all equipment to be used by applicant for providing construction and demolition debris collection service within the City of Gainesville for the service period indicated below.

Service Period: October 1, 2014 thru September 30, 2015

Applicant Information:

Name WATSON C&D LLC
 Address 12890 NE SR 24
 City/State/Zip Code ARCHER, FL 32618
 Phone Number 352-495-9449

TRUCK NUMBER	VEHICLE TYPE (Number of Wheels)	VEHICLE LICENSE TAG	STATE AND COUNTY OF LICENSE TAG
1	MACK CTP713 B 2007 10 WHEEL	N2517N	FLORIDA ALACHUA COUNTY
2	MACK CTP713 B 2007 10 WHEEL	N2516N	FLORIDA ALACHUA COUNTY
3	MACK ET713 2006 10 WHEEL	N8502T	FLORIDA ALACHUA COUNTY
4			
5			
6			
7			



12890 NE State Road 24 • Archer, FL 32618 • (352) 495-9948
www.watsoncll.com  www.facebook.com/WatsonCandD

To whom it may concern,

I Larry R Watson own 95% of Watson C&D LLC along with my daughter Tammy Dabney which owns 5%.

Sincerely,

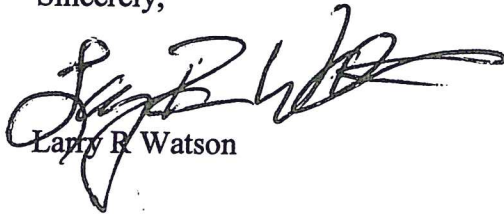
Larry R Watson

STATE OF FLORIDA
COUNTY OF ALACHUA

The foregoing instrument was acknowledged me this 20th day October, in the year 2014, by Larry Watson, President, respectively, of Watson C&D LLC, a Florida corporation, on behalf of the corporation. They/he/she are/is personally known to me or has produced _____ as identification.

Print Name: Turi Stevens

Notary Name, State of Florida

My Commision Expires: 8/1/2017

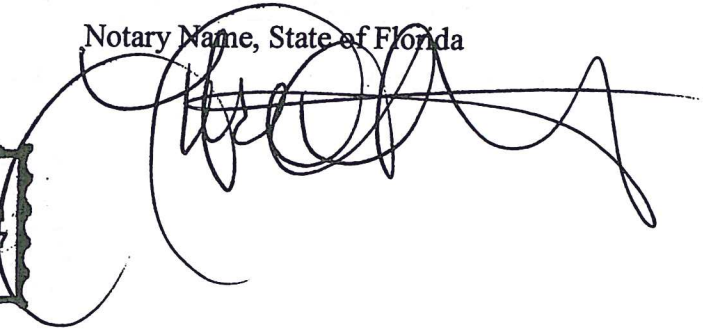



WAIVER OF LIEN

The undersigned, for and in consideration of the sum of Dollars (\$ 475⁰⁰) and other valuable considerations, the receipt of which are hereby acknowledged, does hereby waive, release and remise any and all lien rights, both statutory or equitable, possessed by the undersigned and relating to the following described property owned by New Atlantic Builders, Inc. to wit:

LOTS 118, 160, 99 WESCHESTER

The undersigned acknowledges and understands that the execution of this instrument releases and waives all lien rights whether perfected or unperfected, past or future, relating to the above-described real property.

DATED this the 17th day of October, 2014.

WATSON C & D
Name of claimant or lienor
By: [Signature]
Larry Watson
Name of Person Signing
President
Title of Person Signing

STATE OF FLORIDA
COUNTY OF Alachua

The foregoing Waiver of Lien was acknowledged before me by Larry Watson
as President of Watson C & D LLC
on the 17th day of October, 2014. The Acknowledger () is personally known to me; or
() produced _____ as identification.



[Signature]
NOTARY PUBLIC, State of Florida
Turi Stevens
Printed Name
My Commission Expires: 8/1/2017



CERTIFICATE OF LIABILITY INSURANCE

DATE (MM/DD/YYYY)
10/20/2014

THIS CERTIFICATE IS ISSUED AS A MATTER OF INFORMATION ONLY AND CONFERS NO RIGHTS UPON THE CERTIFICATE HOLDER. THIS CERTIFICATE DOES NOT AFFIRMATIVELY OR NEGATIVELY AMEND, EXTEND OR ALTER THE COVERAGE AFFORDED BY THE POLICIES BELOW. THIS CERTIFICATE OF INSURANCE DOES NOT CONSTITUTE A CONTRACT BETWEEN THE ISSUING INSURER(S), AUTHORIZED REPRESENTATIVE OR PRODUCER, AND THE CERTIFICATE HOLDER.

IMPORTANT: If the certificate holder is an ADDITIONAL INSURED, the policy(ies) must be endorsed. If SUBROGATION IS WAIVED, subject to the terms and conditions of the policy, certain policies may require an endorsement. A statement on this certificate does not confer rights to the certificate holder in lieu of such endorsement(s).

PRODUCER Arthur J. Gallagher Risk Management Services, Inc. 4904 Eisenhower Blvd., Ste 250 Tampa, FL 33634 Ronald Walters	1-727-797-4190	CONTACT NAME: Gini Morgan PHONE (A/C No. Ext): 727-796-6216 E-MAIL ADDRESS: gini_morgan@ajg.com	FAX (A/C No): 727-791-1613
INSURED Watson Construction Company, LLC Watson C&D, LLC, Countyline Landfill, LLC Watson Equipment, LLC 940 NW 247th Drive Newberry, FL 32669		INSURER(S) AFFORDING COVERAGE	
		INSURER A: PROPERTY & CAS INS CO OF HARTFORD	NAIC # 34690
		INSURER B: STARR IND & LIAB CO	38318
		INSURER C: BRIDGEFIELD EMPLOYERS INS CO	10701
		INSURER D: AGCS MARINE INS CO	22837
		INSURER E:	
		INSURER F:	

COVERAGES CERTIFICATE NUMBER: 41869771 REVISION NUMBER:

THIS IS TO CERTIFY THAT THE POLICIES OF INSURANCE LISTED BELOW HAVE BEEN ISSUED TO THE INSURED NAMED ABOVE FOR THE POLICY PERIOD INDICATED. NOTWITHSTANDING ANY REQUIREMENT, TERM OR CONDITION OF ANY CONTRACT OR OTHER DOCUMENT WITH RESPECT TO WHICH THIS CERTIFICATE MAY BE ISSUED OR MAY PERTAIN, THE INSURANCE AFFORDED BY THE POLICIES DESCRIBED HEREIN IS SUBJECT TO ALL THE TERMS, EXCLUSIONS AND CONDITIONS OF SUCH POLICIES. LIMITS SHOWN MAY HAVE BEEN REDUCED BY PAID CLAIMS.

INSR LTR	TYPE OF INSURANCE	ADDL INSR	SUBR WVD	POLICY NUMBER	POLICY EFF (MM/DD/YYYY)	POLICY EXP (MM/DD/YYYY)	LIMITS	
A	GENERAL LIABILITY <input checked="" type="checkbox"/> COMMERCIAL GENERAL LIABILITY <input type="checkbox"/> CLAIMS-MADE <input checked="" type="checkbox"/> OCCUR GEN'L AGGREGATE LIMIT APPLIES PER: <input type="checkbox"/> POLICY <input checked="" type="checkbox"/> PRO-JECT <input type="checkbox"/> LOC			210ENQT3099	02/20/14	02/20/15	EACH OCCURRENCE	\$ 1,000,000
							DAMAGE TO RENTED PREMISES (Ea occurrence)	\$ 300,000
							MED EXP (Any one person)	\$ 10,000
							PERSONAL & ADV INJURY	\$ 1,000,000
							GENERAL AGGREGATE	\$ 2,000,000
							PRODUCTS - COMP/OP AGG	\$ 2,000,000
								\$
A	AUTOMOBILE LIABILITY <input checked="" type="checkbox"/> ANY AUTO <input type="checkbox"/> ALL OWNED AUTOS <input type="checkbox"/> HIRED AUTOS <input type="checkbox"/> SCHEDULED AUTOS <input type="checkbox"/> NON-OWNED AUTOS			210ENQT3100	02/20/14	02/20/15	COMBINED SINGLE LIMIT (Ea accident)	\$ 1,000,000
							BODILY INJURY (Per person)	\$
							BODILY INJURY (Per accident)	\$
							PROPERTY DAMAGE (Per accident)	\$
								\$
B	UMBRELLA LIAB <input checked="" type="checkbox"/> OCCUR EXCESS LIAB <input checked="" type="checkbox"/> CLAIMS-MADE DED RETENTION \$			1000020717	02/20/14	02/20/15	EACH OCCURRENCE	\$ 5,000,000
							AGGREGATE	\$ 5,000,000
								\$
C	WORKERS COMPENSATION AND EMPLOYERS' LIABILITY ANY PROPRIETOR/PARTNER/EXECUTIVE OFFICER/MEMBER EXCLUDED? (Mandatory in NH) If yes, describe under DESCRIPTION OF OPERATIONS below		Y/N N	830-53178 830-49865	01/01/14 01/01/14	01/01/15 01/01/15	<input checked="" type="checkbox"/> WC STATUTORY LIMITS	OTHER
							E.L. EACH ACCIDENT	\$ 1,000,000
							E.L. DISEASE - EA EMPLOYEE	\$ 1,000,000
							E.L. DISEASE - POLICY LIMIT	\$ 1,000,000
D	Property/Inland Marine			MXI93038765	02/20/14	02/20/15	Leased Equipment	500,000

DESCRIPTION OF OPERATIONS / LOCATIONS / VEHICLES (Attach ACORD 101, Additional Remarks Schedule, if more space is required)

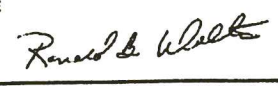
CERTIFICATE HOLDER City of Gainesville; Public Works Department Solid Waste Division, MS10 405 NW 39 Avenue Gainesville, FL 32609 USA	CANCELLATION SHOULD ANY OF THE ABOVE DESCRIBED POLICIES BE CANCELLED BEFORE THE EXPIRATION DATE THEREOF, NOTICE WILL BE DELIVERED IN ACCORDANCE WITH THE POLICY PROVISIONS.
	AUTHORIZED REPRESENTATIVE 



12890 NE State Road 24 • Archer, FL 32618 • (352) 495-9948

www.watsonccl.com



www.facebook.com/WatsonCandD

March 3, 2015

Dana L. Gauthier, CPM
Senior Buyer
GRU
PO Box 147117 Station A130
Gainesville, FL 32614

Subject: Clarification of responses needed to GRU RFP 2015-024 Transportation and Beneficial Reuse or Disposal of Dewatered Biosolids.

Dear Ms. Dana Gauthier:

Watson C&D will use our existing compost facility to process GRU biosolids. The biosolids would be mixed with the compost and processed to A or AA biosolids to enhance the product we currently produce. We are currently engaged with the City and County receiving the curbside vegetative yard waste and tree debris. We are also engaged with GRU Murphee Water Plant receiving the spent lime for water purification, as well as receiving the grit extracted from GRU WWTP's carousels. As our reply to GRU-RFP 2015-024 states, we have a FDEP approved and permitted pilot study for biosolids (see attachment A). We have not yet completed the Pilot Study but feel we can complete this before the centrifuge thickener is ready for use. Watson C&D also has 5,000 acres that can be utilized for land application for Class B Digested.

Please see the requested clarifications listed below.

1. Please confirm the price of \$34.50/wet ton of biosolids over a 5 year contract period is with no annual escalation or fuel adjustment charges.
The price of \$34.50/ wet ton is the price quoted. In our haste trying to complete the bid by cutoff, we did not put a fuel charge in the bid. We interpreted from the RFI there would be a face to face conference with eligible responders to discuss the specific cost of operation increases.
2. Is Watson C&D able to receive Partially Digested biosolids or does your company require GRU to provide Class B Digested biosolids (Pathogen Reduction level)? If you can take partially digested biosolids, does the \$34.50/ wet ton price still apply?
At present time we would have to request Class B Digested Pathogen-Reduced, that we could land apply. We are diligently working to complete the FDEP Pilot Study which would confirm we could take Partially Digested biosolids. At this point, \$34.50 would still apply.
3. Do you have FDEP approval for your process for receiving biosolids at Partially Digested levels?
Yes, we currently have a FDEP approval for receiving Waste Activated Sludge to be processed to A or AA standard.

4. Do you have FDEP approval for your process for biosolids at Digested Class B (Pathogen Reduction levels)?
Yes, same as #3.
5. Item 6.1 Description of Proposed Process
- Can you clarify what you mean by “Watson C&D would prefer to receive Digested Class B biosolids, but pending results of a pilot program with waste activated sludge, would be able to receive either one”?
6.1 At present time we have not completed Pilot Study and would be able to start operations by land applying Class B. After Pilot Study demonstrates waste activated sludge can be processed to A or AA we would be in a position to accept either Class B Digested or Partially Digested biosolids.
6. Item 6.4 (d) Risk of Process Disruption
- You stated that your contingency plan in case of process disruption/ failure was “in case of surplus, land application for feed farmers would be a contingency plan”. Please describe how you would treat the biosolids in this situation in order to be able to land apply.
6.4 Watson C&D presently has 5000 acres of farm land that can be permitted to land application before proposed start date of centrifuge dewatering.
 - Can you clarify what you mean by “while an in-vessel composter was constructed to accommodate the biosolids overage”? How are you planning to use the in-vessel composter? Are you planning to utilize in-vessel composting to treat Partially Digested biosolids volumes which cannot be land applied?
Watson C&D owns an in-vessel composter which is being modified and installed. Watson C&D would use this to process Class B digested to Class A or AA.
7. Can you provide a valid business tax receipt issued by the City of Gainesville at least 6 months prior to the response due date?
Please see attached (attachment C) which is our Newberry license. We apologize but were under the impression that this encompassed Alachua County. If necessary we will apply for the County or City of Gainesville licenses, whichever is required.

Sincerely,

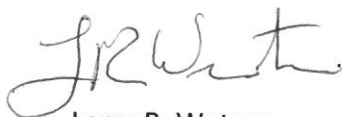

Larry R. Watson
Watson C&D, LLC

**Plan of Study
For A
Biosolids Composting
Feasibility Study**



**Watson C&D LLC
12890 NE SR24
Archer, Fl 32618**

**Prepared By:
Henry A. Sheldon, P.E.
11611 SW 89th Street
Gainesville, Fl 32608**



November 11, 2014

Contents

Section		Page
1	Purpose	3
2	The Watson Site	4
3	Pilot Study Area	6
4	Aerated Static Piles	9
5	Analyses	13
6	Deliverables	15

Figures

1	Watson Site - Location Map	4
2	Watson Site - Land Use	5
3	Watson Site - Pilot Study Area	6
4	Pilot Study Area - Topography	7
5	Pilot Study Area - Soils	8
6	Aerated Static Piles - Dimensions	10
7	Aerated Static Piles - Layout	11

Tables

1	Aerated Static Piles - Composition	12
2	Weather Conditions	13
3	ASP Physical/Chemical Conditions	13
4	EPA /FDEP Regulated Metals	14
5	EPA Pathogenic Organisms & VA	14
6	Agricultural & Fertilizer Characteristics	14

Section 1

Purpose

Watson C&D is considering upgrading its composting operations to include municipal biosolids. It is Watson's goal to improve the 'fertilizer' value of their marketable compost by incorporating into it municipal biosolids.

Ingredients of Watson's present compost product include:

- (A) Vegetative Yard Waste (VYW) - Curbside pickup of grass clippings, leaves, tree limbs, etc.,
- (B) Vegetative Produce Waste (VPW) - Grocery store waste vegetables, etc, and
- (C) Animal Waste (AW) - Dairy Cow Manure.

The compost from these organics, although being a valuable (and marketable) soil complement are relatively low in Nitrogen (1%) and Phosphorous (0.5%). Municipal biosolids having higher concentrations of nitrogen (5%) and phosphorous (3%) would improve the fertilizer value of the compost.

The Purpose of this Feasibility (Pilot) Study is to demonstrate that Watson C&D can produce at its Archer Road (SR 24) Site in Levy County a compost including municipal biosolids that will comply with all EPA Class A (FDEP Class AA) biosolid standards and requirements thus enabling it to be marketed in the public domain. The Study will be based on the use of Aerated Static Piles (ASPs).

Section 2

The Watson Site

The Watson Site is located on SR24 in Levy County as shown in Figure 1.

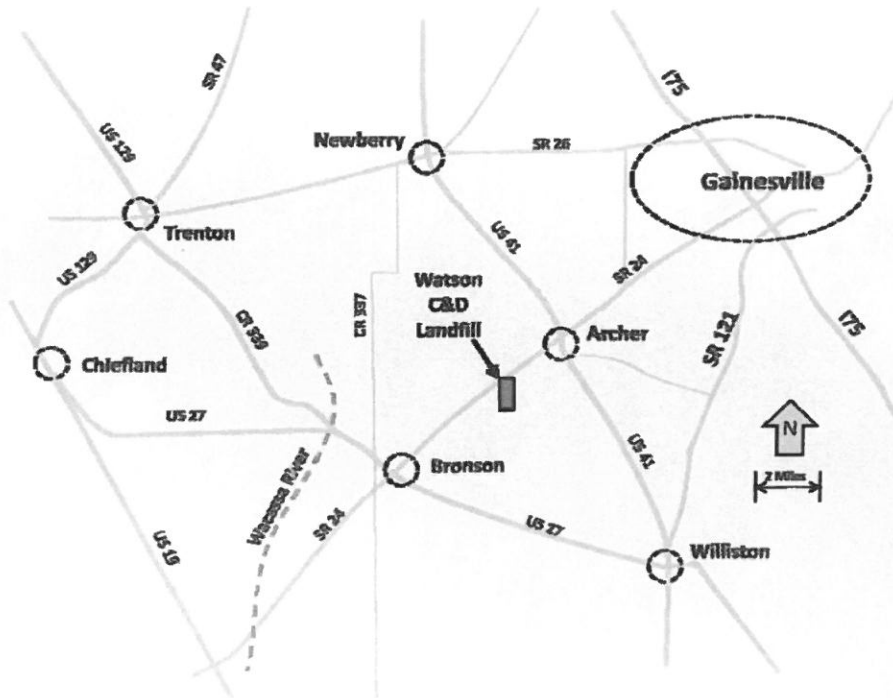
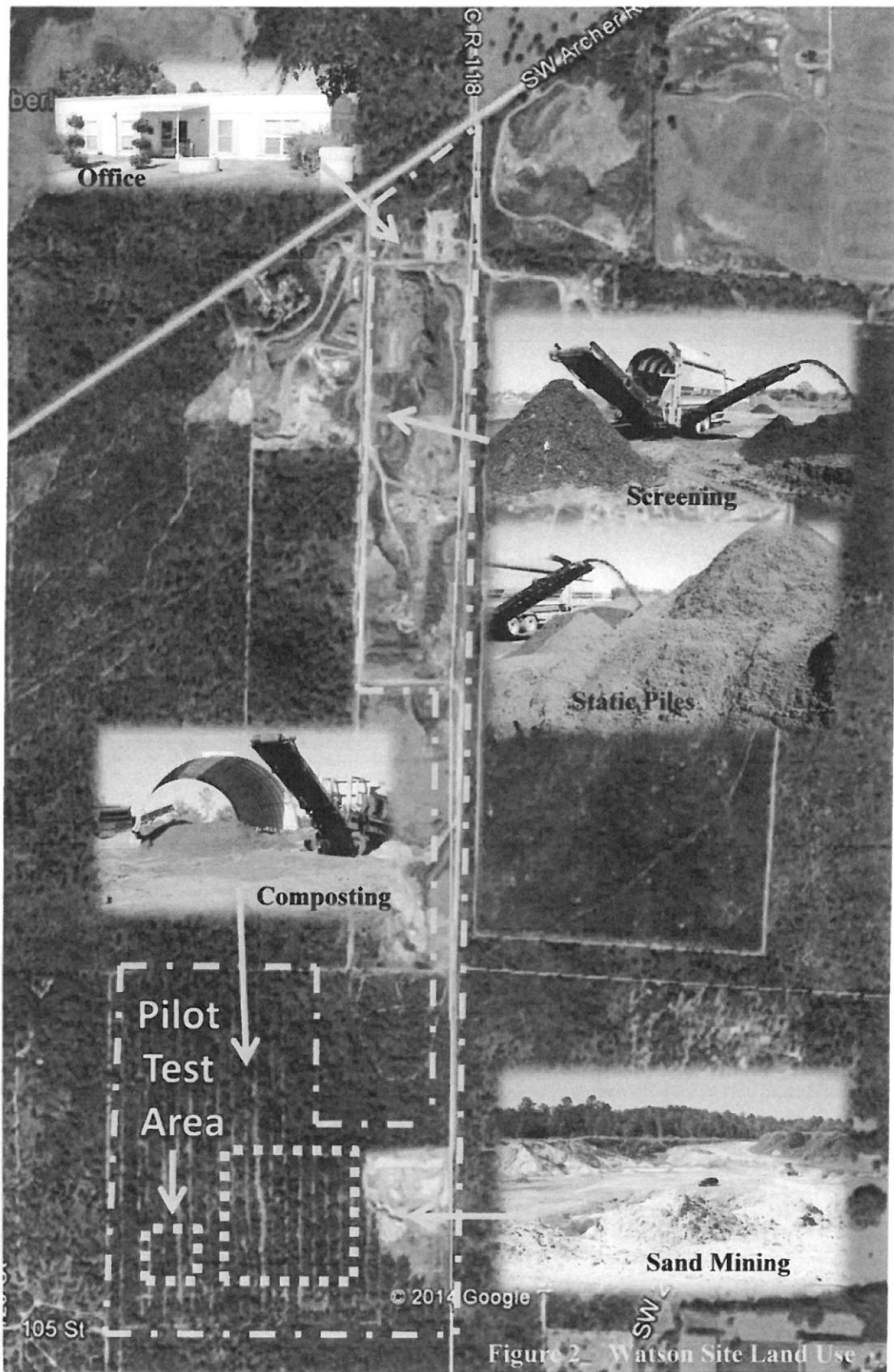

Figure 1 Watson Site - Location Map

The Site consists of approximately 200 acres and includes several multi-use areas listed below. An aerial base map of the Site delineating these use areas is shown Figure 2.

A.	An active sand mining area (Ac)	40
B.	An active composting area (Ac)	80
C.	An active landfill area (Ac)	40
D.	An office & commercial outlet sales area (Ac)	5
E.	An equipment storage and maintenance yard (Ac)	5
F.	Forested expansion areas, roads, & buffers (Ac)	<u>30</u>
	Total (Ac) =	200



3.2 Topography - Topography (ground slopes) of the Pilot Study Area is shown in Figure 4. Ground slopes in the Test Area are less than 3%. The Pilot Study Area has been cleared and grubbed with 4 to 6 inches of top soil from the Area formed in to a 3 foot high berm adjacent to the Forested Property Line Buffer Zone.

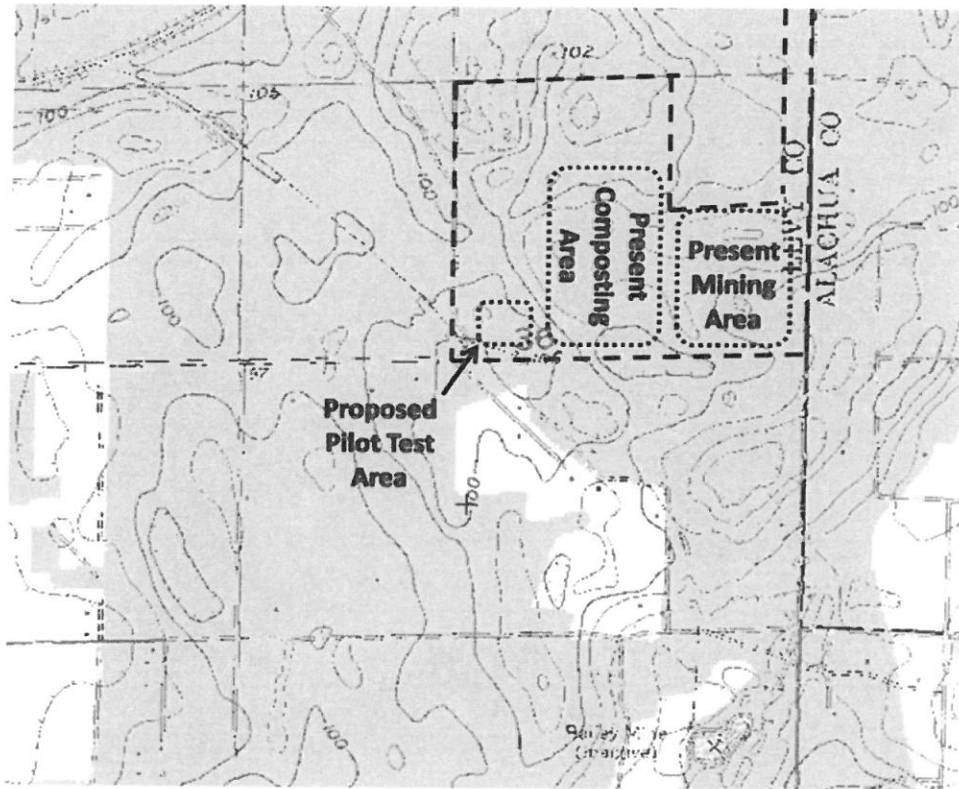

Figure 4 Pilot Study Area - Topography (USGS)



Pilot Study Area - Cleared & Grubbed

3.3 Soils - Soils in the immediate area of the Pilot Study area are shown in Figure 5. The predominant soil in the Test Area is Chandler Fine Sand. This is a deep, clean, well drained, permeable sand to depths of 50 feet. Surface slopes are less than 5%.

Chandler Fine Sand is a 'beach sand' of Florida's Miocene Shoreline (5 Million Years Ago). It is the primary sand being mined at the Watson Site. It is commonly used in the local area for building foundations.

Soils in the Pilot Test area will remain in their natural state (profile) for duration of the Pilot Study and beyond as necessary to support future compost operations.

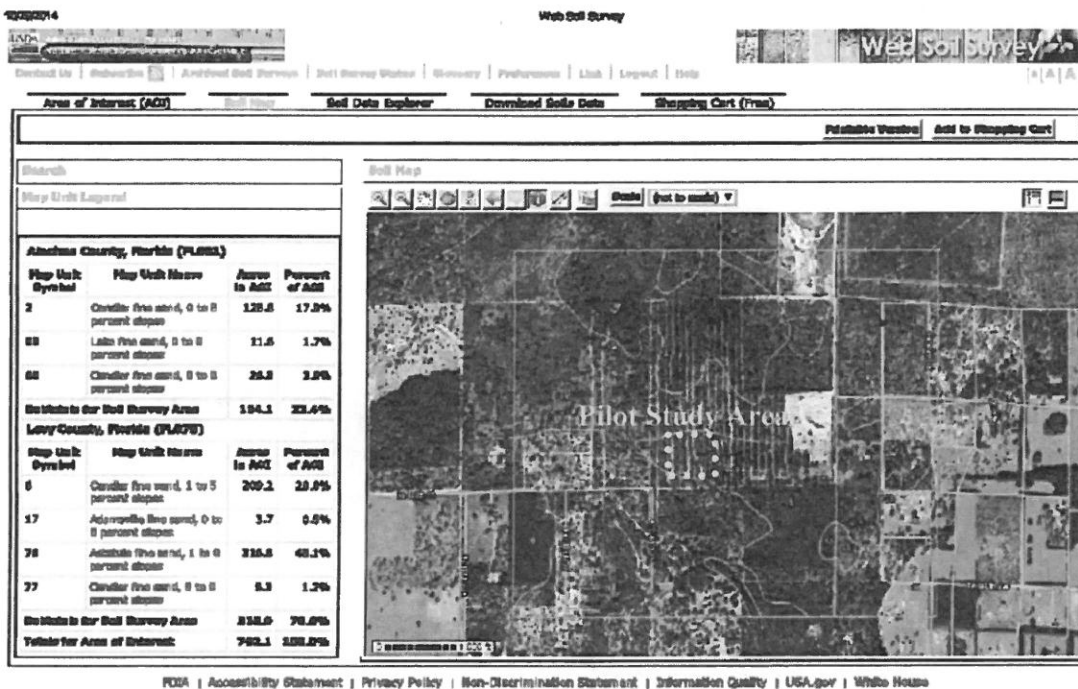

Figure 5 Pilot Study Area - Soils (Source: NRCS)

3.4 Setbacks - All Pilot Test features (ASP's as described below) will be set back from property lines, private wells, surface water as required by FDEP 62-630. Specifically, these setbacks will include the following:

- A. **Property Lines** - The Pilot Test Area will be setback a minimum of 200 feet inside the South and West Property Line. The setback area will be maintained in natural pine/palmetto forest cover.
- B. **Private Wells** - The Pilot Test Area will be setback a minimum of 300 feet from any private wells in the area.
- C. **Sinkholes & Surface Waters** - None Identified within 500 feet of Property Line.

Section 4

Aerated Static Piles

The Pilot Study will utilize Aerated Static Piles (ASP) to achieve compliance with the EPA 503 and FDEP 62-640 Regulations. The Pilot Study will include Nine (9) Piles as described below. Each Pile will be aerated by mixing (scooping and dropping) with a Front-End Loader.

4.1 Shape, Dimensions, and Volume - Each ASP will be formed into a pyramid of approximate dimensions as shown in Figure 6. These dimensions are Watson's 'Standard Dimensions' for their current Static Piles.

Mathematically this shape (Pile) is a 'Prismatoid'. Its 'True' volume (V_1) is calculated by the equation: $V_1 = (1/3)h(B_1+B_2+\sqrt{B_1 \times B_2})$, where h = high (ft) of the Pile, B_1 = Area (sf) of the Base of the Pile, and B_2 = Area (sf) of the top of the Pile.

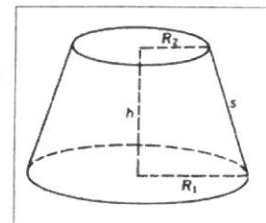

At the start of the Test, i.e., at Time (T) = 0 days, the Pile's approximate dimensions (based on Watson's experience) will be $h = 15$ feet, $D_1 = 36$ feet, and $D_2 = 8$ feet, where D_1 and D_2 are the diameters of the base and top respectively. The calculated 'True' volume (V_1) of a perfectly formed ASP to these dimensions is: $V_1 = 239$ CY. [30 perfect 8 CY 'scoops']

The actual ASP will be imperfect in shape due to it being constructed with a 'Front-End Loader' with an 8 CY bucket (scoop). Given the 'Reach' of the 'loader', the dexterity of the operator, weather, and other factors of construction, the standard ASP volume at $T=0$, will be assumed to be 224 CY based on 28 '8 CY scoops' with the Front-End Loader. The ASP will be approximately 94% 'perfect' in shape and volume.

Based on Watson's experience with their current composting of static Piles, there will be an approximate 60% to 70% volumetric reduction of the pile at the completion of the composting reaction in 100 to 120 days depending on weather. The volume (V_2) of the stabilized (composted) ASP is therefore estimated to be between 65 and 90 CY. The dimensions of the V_2 ASP shown in Figure 6 are rough approximations of the stabilized (composted) ASP.

For the purposes of this Study, the ASP's will be composted without bacterial assist occulants. Only moisture will be added as needed to maintain pile temperatures to the EPA/FDEP minimum standards of 55° C [122° F] for 15 days with mixing as sufficient to achieve Pathogen and Vector Attraction Reduction.

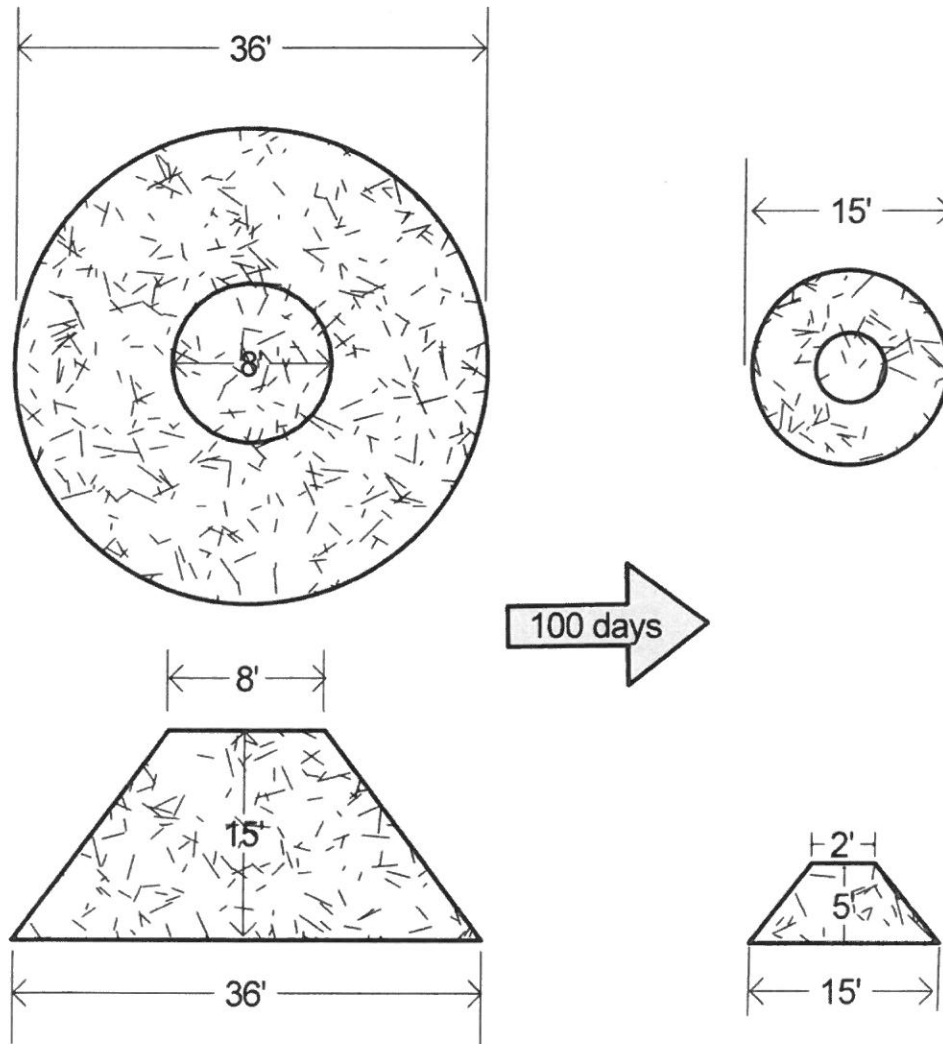

Note: Volumetric Reduction Estimated w/o Occulents

Figure 6 ASP Dimensions (Typical)

4.2 Spatial Layout - Layout of the 9 Piles will be based on 100-foot centers as shown in Figure 7. The total space requirement is estimated at 300' x 300' or approximately 2 Acres.

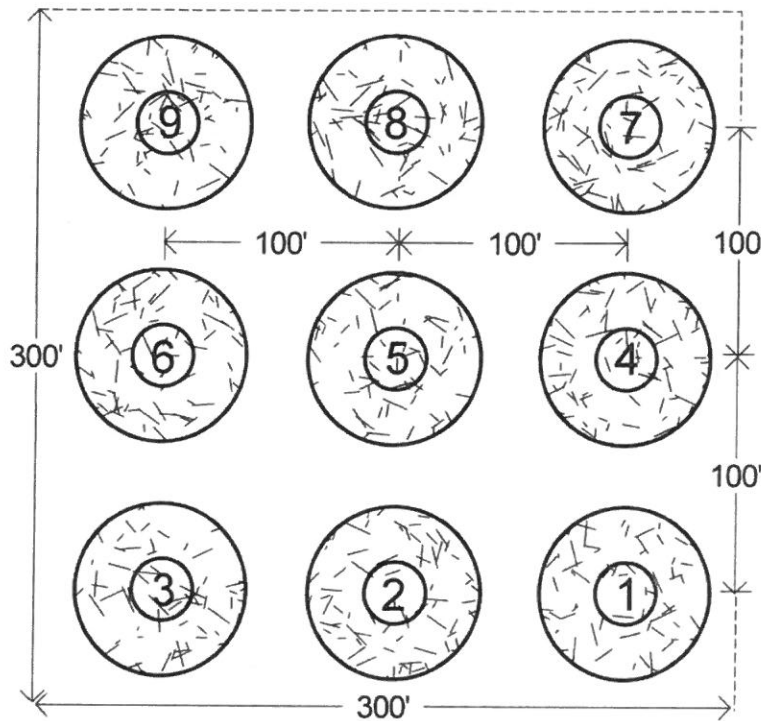

Figure 7 ASP Spatial Layout

4.3 Composition - Raw materials to be used in the ASP composting reactions will include the following:

- A. Non-Pathogenic Organics
 - i. VYW - Curbside grass clippings, leaves, twigs, etc.
 - ii. VPW - Pre-consumer waste vegetable produce - lettuce, tomatoes, etc.
 - iii. AW - Dried Cow Manure (dairy originated solid waste)
- B. Pathogenic Organics
 - i. Class B Dewatered Municipal Biosolids (BS)
- C. Wood Ash Inorganics

All of these ingredients with the exception of the Biosolids are currently available at the Watson Site being used for composting or other purposes. Municipal Biosolids will be obtained (hailed) from the City of Lake City's St. Margaret Road WWTP. The Lake City Biosolids meet FDEP Class B Standards as they leave the WWTP in Lake City as summarized below. Table 1 summarizes the proposed composition of each of the nine (9) ASP's.

Table 1 Composition of Static Piles (% & Scoops)

Pile	Pile Mix (%)				
	Curbsides (VYW)	Vegetables (VPW)	Manure (AW)	Wood Ash (WA)	Biosolids (BS)
1	100	0	0	0	0
2	70	30	0	0	0
3	60	30	10	0	0
4	70	0	0	0	30
5	50	0	0	0	50
6	30	0	0	0	70
7	40	20	10	10	20
8	40	0	0	10	50
9	0	0	0	0	100

Pile	Pile Mix (8 CY Scoops)				
	Curbsides (VYW)	Vegetables (VPW)	Manure (AW)	Wood Ash (WA)	Biosolids (BS)
1	28	0	0	0	0
2	20	8	0	0	0
3	17	8	3	0	0
4	20	0	0	0	8
5	14	0	0	0	14
6	8	0	0	0	20
7	11	4	4	4	5
8	11	0	0	3	14
9	0	0	0	0	28

Section 5

Analyses

Analyses will be conducted of Watson's Compost to demonstrate compliance with EPA and FDEP Requirements for Use in the Public Domain as follows:

5.1 On-Site Analyses by Staff

On-Site Analyses by Staff will include recording daily ambient weather conditions at the Watson Site (Office Building Weather Station) and periodic Physical Conditions of the ASP's as shown in Tables 2 and 3. ASP Temperature and pH analyses will be made by hand-held probes of representative locations inside the ASP.

Table 2 Weather Conditions (Daily -1400 @ Office)

Date	Temp (F)	Rainfall (In)	Clear (√)	Windy (√)	Overcast (√)

Table 3 Physical/Chemical Conditions of ASP's (Weekly @ 1400 Hour)

Date:	Aerated Static Piles (ASPs)								
	1	2	3	4	5	6	7	8	9
Temp (F) ¹									
pH									
Moisture ¹									
Moisture Added (√)									
Vectors (√)									
Odors (√)									
Other Observations									

1) Temperature & Moisture taken with 4' probes inside Pile.

5.2 Analyses by Certified Laboratories

Analyses by Certified Laboratories will be made of the following physical and chemical properties of each ASP as summarized in Tables 4, 5, & 6.

**Table 4 EPA Regulated Metals
(Representative Samples at T=0 and T=100 days)**

Metals	Aerated Static Piles (ASPs)								
	1	2	3	4	5	6	7	8	9
Arsenic									
Cadmium									
Copper									
Lead									
Mercury									
Molybdenum									
Nickel									
Selenium									
Zinc									

**Table 5 EPA Pathogenic Organism & Vector Attraction Reduction Compliance
(Representative Samples from each ASP at T=0, T=5, T=15, & T= 45, T = 60, & T = 100 days)**

Parameter	Aerated Static Piles (ASPs)								
	1	2	3	4	5	6	7	8	9
Fecals									
Salmonella									
SOUR's									

**Table 6 Agricultural Value & Fertilizer Characteristics
(Representative Samples at T=0 and T=100 days)**

Parameter	Aerated Static Piles (ASPs)								
	1	2	3	4	5	6	7	8	9
pH									
Nitrogen									
Phosphorous									
Potassium									
Iron									
Sulfur									
Calcium									
Magnesium									
Manganese									
Boron									
TDS									

Section 6

Deliverables

Deliverables to FDEP will include the following reports and documents:

1. Quarterly Report summarizing all Study activities, results, and conclusions in narratives, graphs, and photographs.
2. Final Report
3. FDEP Permit Application

All reports will be signed and sealed by the Engineer of Record for the project as required by Florida Statutes & the Florida Administrative Code.



**STATE OF FLORIDA
DEPARTMENT OF BUSINESS AND PROFESSIONAL REGULATION**

**CONSTRUCTION INDUSTRY LICENSING BOARD
1940 NORTH MONROE STREET
TALLAHASSEE FL 32399-0783**

(850) 487-1395

**DABNEY, DOUGLAS HALE
WATSON CONSTRUCTION COMPANY, LLC
940 NW 247TH DRIVE
NEWBERRY FL 32669**

Congratulations! With this license you become one of the nearly one million Floridians licensed by the Department of Business and Professional Regulation. Our professionals and businesses range from architects to yacht brokers, from boxers to barbeque restaurants, and they keep Florida's economy strong.

Every day we work to improve the way we do business in order to serve you better. For information about our services, please log onto www.myfloridalicense.com. There you can find more information about our divisions and the regulations that impact you, subscribe to department newsletters and learn more about the Department's initiatives.

Our mission at the Department is: License Efficiently, Regulate Fairly. We constantly strive to serve you better so that you can serve your customers. Thank you for doing business in Florida, and congratulations on your new license!

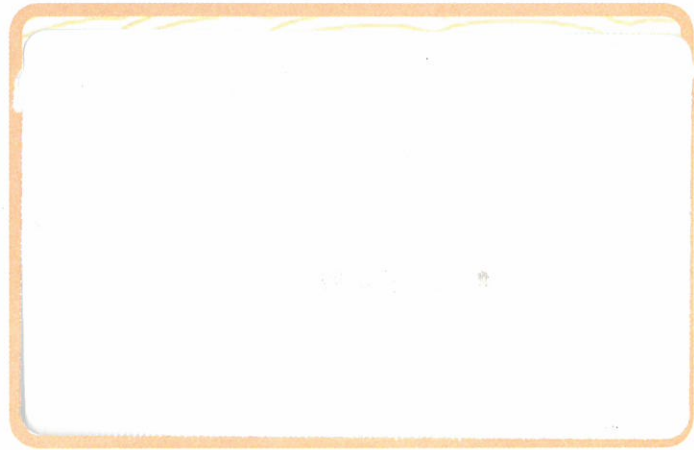

DETACH HERE

RICK SCOTT, GOVERNOR

KEN LAWSON, SECRETARY

**STATE OF FLORIDA
DEPARTMENT OF BUSINESS AND PROFESSIONAL REGULATION
CONSTRUCTION INDUSTRY LICENSING BOARD**

LICENSE NUMBER

CGC1510498

The GENERAL CONTRACTOR
Named below IS CERTIFIED
Under the provisions of Chapter 489 FS.
Expiration date: AUG 31, 2016

**DABNEY, DOUGLAS HALE
WATSON CONSTRUCTION COMPANY, LLC
940 NW 247TH DRIVE
NEWBERRY FL 32669**

