

City of  
Gainesville

Inter-Office Communication

Department of Community Development  
x2034, FAX x2282, Station 11

To: Carl Harness, Assistant City Manager

Date: May 26, 1999

From: Rick D. Smith, Historic Preservation Planner

Subject: **Petition 28COA-99HPB.** Erect lighting for Roper Park located in the 200 block of NE 4<sup>th</sup> Avenue in the Northeast Residential Historic District. City of Gainesville, Owner and Agent.

At its May 4, 1999, public meeting the City of Gainesville Historic Preservation Board approved the above proposal with the following conditions:

- *The applicant comply with all the applicable codes of the City of Gainesville; and*
- *Relocate the lights in the manner indicated on the attachment.*

The recommendation was based on the following findings:

- *The proposal complies with the Secretary of Interior's Standards for Rehabilitation and Illustrated Guide for Rehabilitating Historic Buildings because it will not remove or radically change features that define the site, namely the formal quality conveyed by the walkways which center on the azaleas; and*
- *The recommendations to relocate the position of the lamps is designed to provide definition to the corners of Roper Park and focus on its center.*

**Gainesville Police Department  
Inter-Office Communication**

**Chief Donald L. Shinnamon, Sr.**

---

**To:** Carl Harness  
Assistant City Manager

**Date:** 03-25-99

**From:** Officer Joseph Wise #133  
Crime Prevention Division (ext. 2479)

**Subject:** Lighting in Roper Park

In regards to your request for input regarding the feasibility of additional lighting in Roper Park.

As it stands, additional lighting is warranted in the area to provide a safer environment for visitors. Special consideration should be given to pedestrian oriented lighting along sidewalks identified as primary routes for pedestrians "cutting through" the park after dark.

It is recommended that any lighting in the park be placed on timers set to turn lights off no later than 11:30PM in accordance with City ordinance 18-19(a) setting forth hours of operation for City parks. It is further recommended that any lights be placed below the tree line for maximum visibility.

The Gainesville Police Department supports any plan aimed at achieving the above stated goals. We would be happy to assist staff in selecting the most appropriate type of lighting and locating it for maximum benefit. Please contact my office at 334-2479 with any questions or concerns.

NE 5th Avenue

Jungle Gym  
Playground

Play  
Unit

Azaleas

NE 2nd Street

NE 3rd Street

NE 4th Avenue





= Light Fixture



= Existing Street Light

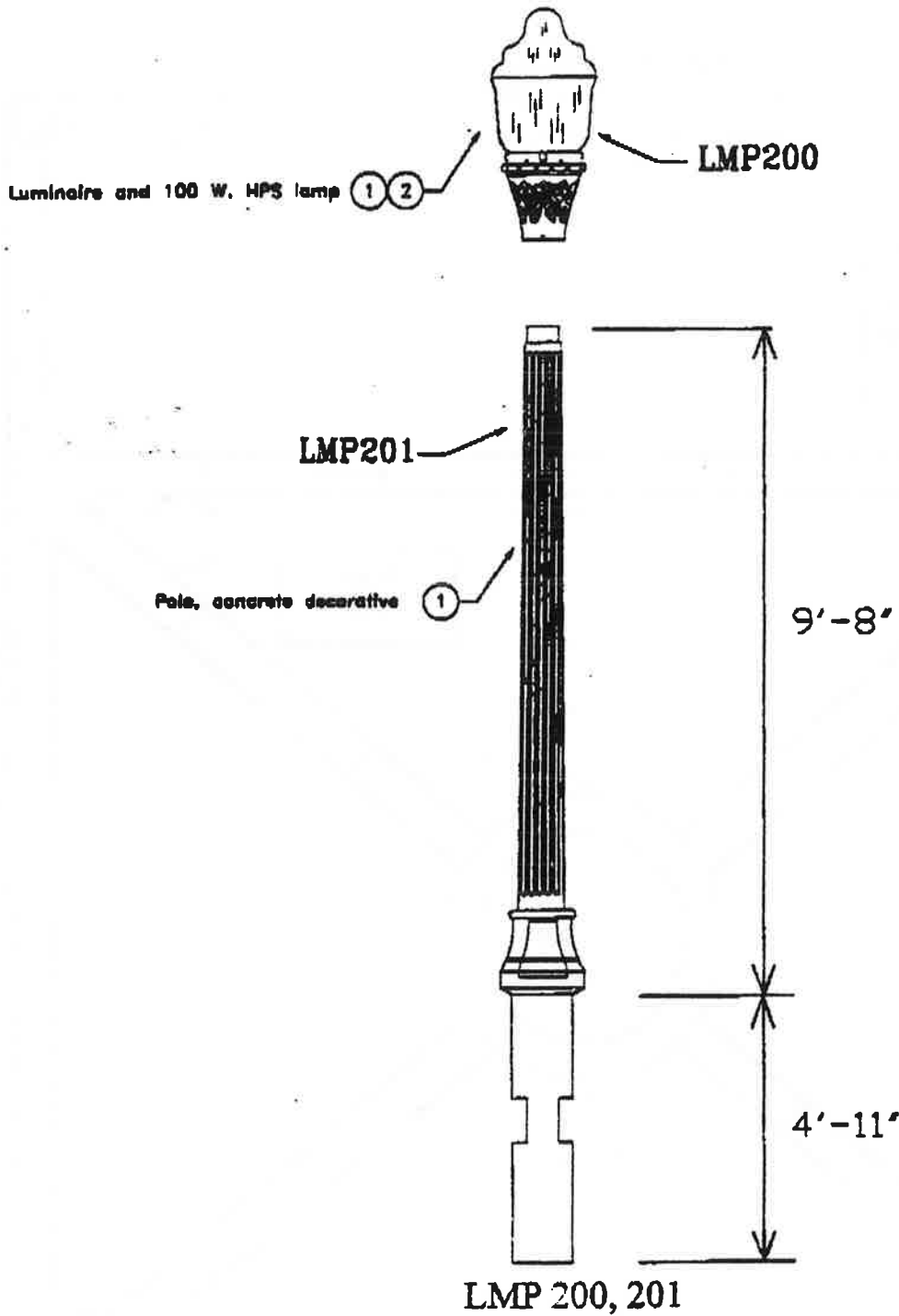



Revision Date: 4-30-98 1-8-99		Gainesville Regional Utilities Electric Distribution Construction Standards Manual	
		Luminaire, 100W High Pressure Sodium Decorative (& Pole)	Assembly LMP--